

LK01-A LIQUID FLOW SWITCH

DESCRIPTION

LK01-A Liquid Flow Switch is used in the circumstance where chain effect or cut-off protection is needed. It is to supervise the liquid flow rate through the pipes. When liquid inside the pipe circulates or cuts off, flow switch will correspondingly alters the ON/OFF state so as to control and protect external devices. Liquid Flow Switch is suitable for any liquid medium that makes no corruption on brass and tin-bronze and takes no effect on air-proof performance.



CHARACTERISTICS

- I Suitable for pipes from 1" to 8"
- I Applicable to cool/heat water system
- I Strong die-casting aluminum alloy casing and cover
- I 1" external screw joint; Easy mounting (NPT, BSP)
- I Dependable and durable parts such as forged brass, tin bronze, stainless-steel and high-strength flameproof engineering plastic
- I Complete airproof design

INSTALLATION

- I Mount on return pipes
- I Mount on horizontal pipes
- I Keep a certain distance from sources of turbulences (Elbows, valves, pumps, etc) so as to ensure steady working flow. Recommended minimum distance is equal to 5 times the pipe's diameter

ADJUSTMENT OF FLOW RATE SETTING

Setting of LK01-A is by means of relative screw. Fully tighten the screw to obtain minimum flow rate setting, fully loosen the screw to have maximum flow rate setting. The following table gives the values for limiting flow rate settings in relation to the pipe diameter and blade length. The LK01-A is supplied ex-factory with the setting screw fully tightened (minimum setting).

DIAMETER (inch)	BLADE LENGTH (mm)	FLOW RATE WITH MINIMUM SETTING (m ³ /h)		FLOW RATE WITH MAXIMUM SETTING (m ³ /h)	
		SWITCH ACTION	SWITCH RETURN	SWITCH ACTION	SWITCH RETURN
1	34	0.9	0.4	2.0	1.5
1 1/4	34	1.2	0.6	2.6	1.9
1 1/2	57	1.6	0.9	3.3	2.6
2	57	3.2	2.2	7.1	5.1
2 1/2	88	4.2	3.5	8.0	7.0
3	88	6.3	5.7	12.0	10.5
4	88	13.5	12.0	28.0	26.0
5	167	12.0	9.0	30.0	28.0
6	167	17.2	12.0	35.0	32.0
8	167	42.0	36.0	90.0	85.0

The pre-set bolt has been adjusted before ex-factory. Users cannot adjust by themselves. The adjustable bolt can be adjusted and set according to practical requirements.
(See Fig. 1)

TECHNICAL DATA

- I Rated voltage, rated current: 250VAC, 10(3)A
- I Working pressure: 1MPa
- I Max. testing pressure: 1.5 MPa
- I Max. fluid temperature: 110°C
- I Storage temperature: -20~80°C
- I Weight: 0.8Kg
- I Protection class of casing: IP64

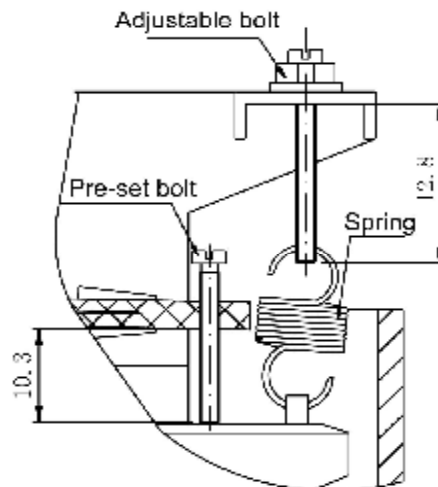

(Fig.1)

MATERIAL

- I Casing and cover: Die-casting aluminum alloyed
- I Bellow: Tin-bronze
- I Blade: Stainless steel
- I Joint: Forged brass, 1" external screw

DIMENSIONS (Fig.2)

- I 1-2 contact is normally closed (When flow switch is working, the contacts disconnect.)
- I 1-3 contact is normally open (When flow switch is working, the contacts connect.)

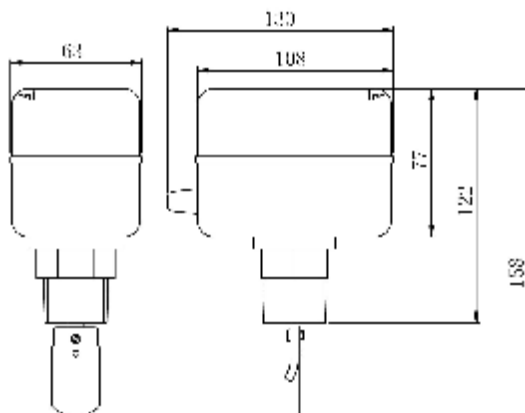

(Fig. 2)

WIRING DIAGRAM

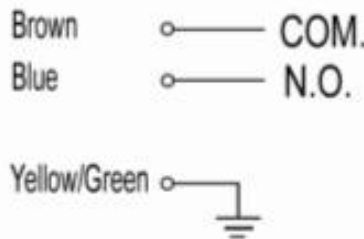
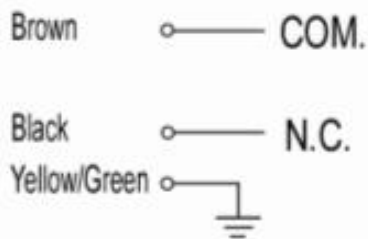

(Fig. 3)

Earth wire (Yellow/Green), Common wire (Brown).
Two live wires: Normally closed contact (black); Normally open contact (blue).