

This is a general specification leaflet; for specific applications not covered herein, contact Suntec.

The SUNTEC AJ oil pump is the basic model incorporating a pressure regulating valve with cut-off*.

APPLICATIONS

- Light oil.
- One or two-pipe system.
- Normally associated with in-line solenoid valve.

SPECIAL FEATURES OF THE REVISION "4"

- Reduced internal pressure losses.
- Sealing at inlet and return ports on the spot face with a washer.

PUMP OPERATING PRINCIPLE

The gear set draws oil from the tank through the built-in filter and transfers it to the valve that regulates the oil pressure to the nozzle line. All oil that does not go through the nozzle line will be by-passed through the valve back to the return line in two pipe installation or, if it is a one-pipe installation, back to the suction port in the gear-set; in that case, the by-pass plug must be removed from the vacuum gauge port and the return port sealed by steel plug and washer.

The valve also has a cut-off function* as follows :

During starting period when the gear-set speed is increasing, all the oil passes through a bleed slot in the piston, back to the return. Once the speed reaches a certain value and the flow can no longer pass through this bleed slot, then the pressure increases rapidly overcoming the valve spring force and opens the valve.

During the stop sequence, the gear-set speed slows down and the valve closes when the gear-set capacity is lower than the bleed slot flow.

The cut-on and cut-off speeds depend on the gear-set size and set pressure.

Bleed :

Bleeding in two pipe operation is automatic, but it may be accelerated by loosening the plug in a pressure gauge port.

In one pipe operation, a pressure port must be opened to bleed the system.

* Owing to the presence of the nozzle by-pass hole, AJ 1002 models have no cut-off function. Cut-off must be provided by an external solenoid valve.

PUMP IDENTIFICATION

(Not all model combinations are available
Consult your Suntec representative)

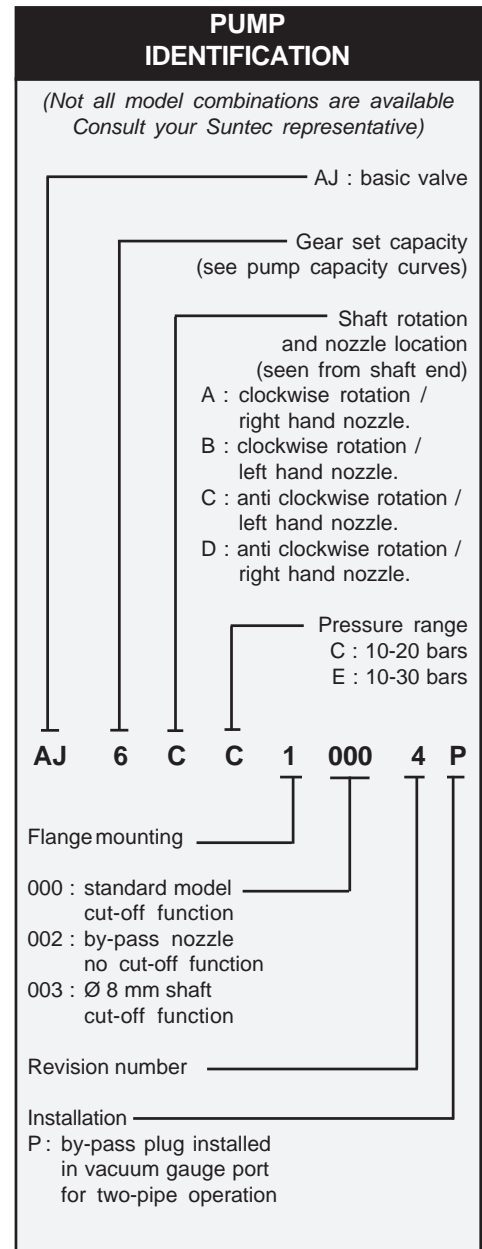

AJ : basic valve

6 : Gear set capacity (see pump capacity curves)

C : Shaft rotation and nozzle location (seen from shaft end)
A : clockwise rotation / right hand nozzle.
B : clockwise rotation / left hand nozzle.
C : anti clockwise rotation / left hand nozzle.
D : anti clockwise rotation / right hand nozzle.

C : Pressure range
C : 10-20 bars
E : 10-30 bars

1 : Flange mounting

000 : standard model cut-off function
002 : by-pass nozzle no cut-off function
003 : Ø 8 mm shaft cut-off function

4 : Revision number

P : Installation
P : by-pass plug installed in vacuum gauge port for two-pipe operation

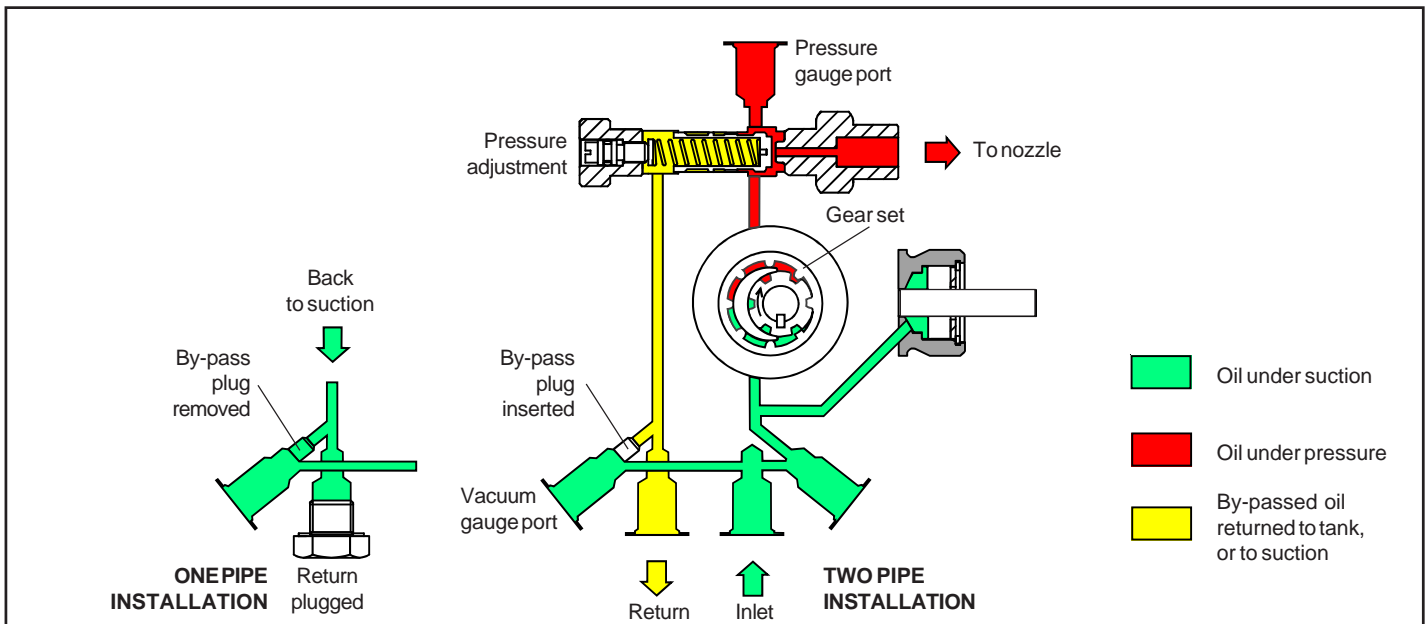

TECHNICAL DATA

General

Mounting	Flange according to EN 225
Connection threads	Cylindrical according to ISO 228/1
Inlet and return	G 1/4
Nozzle outlet	G 1/8
Pressure gauge port	G 1/8
Vacuum gauge port	G 1/8
Valve function	Pressure regulating and cut-off* (* except for 1002 models).
Strainer	Open area : 30 cm ² Opening size : 120 x 150 μm ²
Shaft	AJ 1000/1002 : Ø 11mm (7/16") AJ 1003 : Ø 8 mm according to EN 225.
By-pass plug	Inserted in vacuum gauge port for 2 pipe system; to be removed with a 4 mm Allen key for 1 pipe system.
Weight	1,7 kg

Hydraulic data

Nozzle pressure range	C : 10 - 20 bars E : 10 - 30 bars
Delivery pressure setting	12 bars
Operating viscosity	2 - 75 mm ² /s (cSt)
Oil temperature	0 - 60°C in the pump.
Inlet pressure	2 bars max.
Return pressure	2 bars max.
Suction height	0,45 bars max. vacuum to prevent air separation from oil.
Rated speed	3600 rpm max.
Torque (@ 45 rpm)	0,30 N.m

Pump capacity

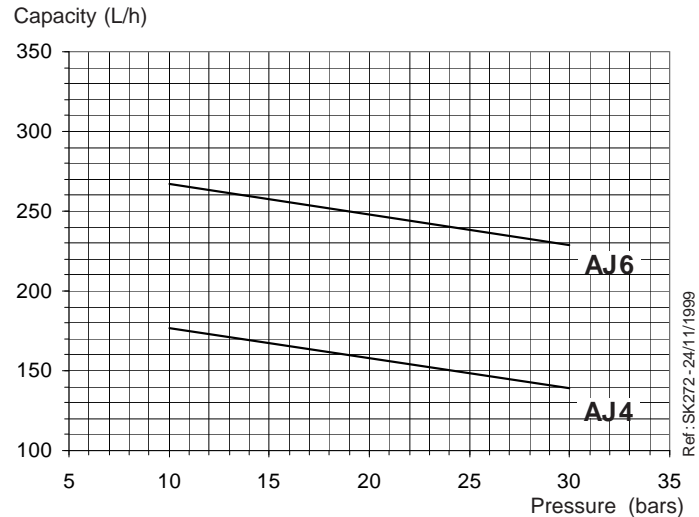

Viscosity = 5 cSt - rated speed = 2850 rpm

Data shown take into account a wear margin.

Do not oversize the pump when selecting the gear capacity.

Power consumption

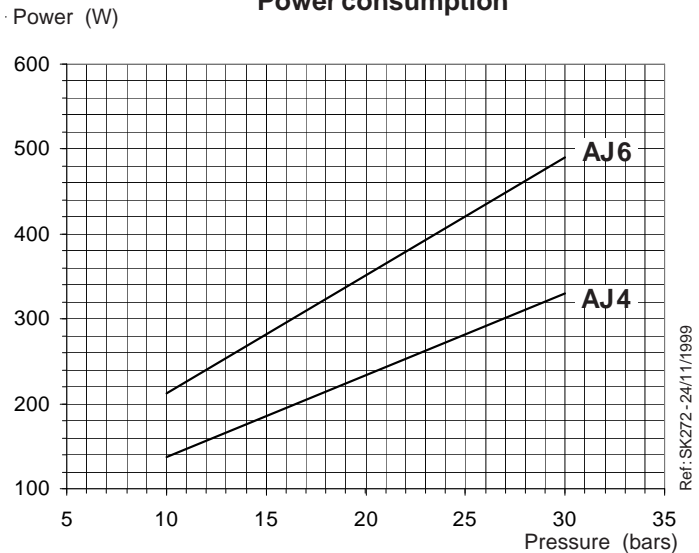

Viscosity = 5 cSt - Rated speed = 2850 rpm

PUMP DIMENSIONS

Example shows "C" rotation and nozzle outlet.

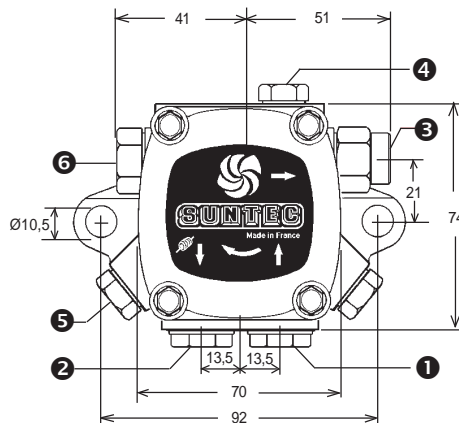
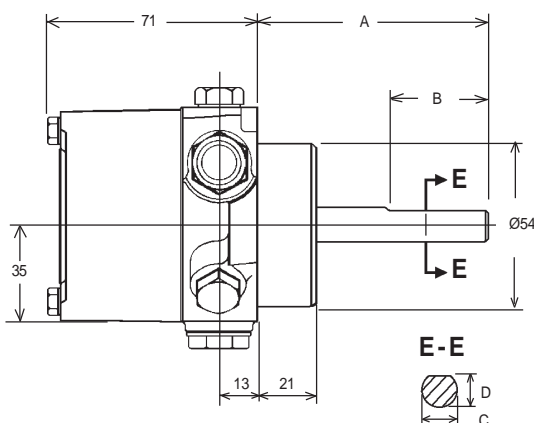

	A (mm)	B (mm)	C Ø (mm)	D (mm)
AJ 1000	80	32	11,07(7/16")	10
AJ 1002	80	32	11,07(7/16")	10
AJ 1003	42	15	8	7

- 1** Suction
2 Return
3 Nozzle outlet
4 Pressure gauge port
5 Vacuum gauge port and internal by-pass plug
6 Pressure adjustment