

Spyder® Lon Programmable, Unitary/VAV Controllers

SPECIFICATION DATA

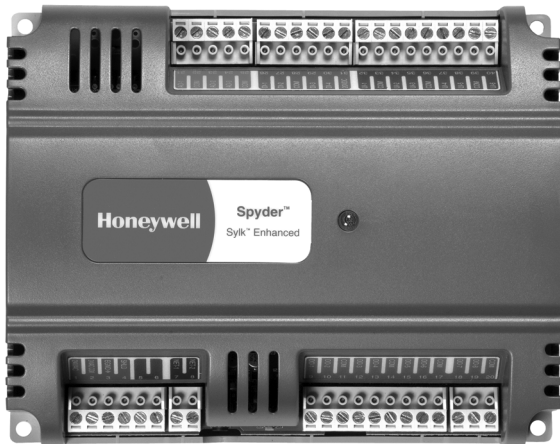

GENERAL

The PUL1012S, PUL4024S, PUL6438S, PVL0000AS, PVL4022AS, PVL4024NS, PVL6436AS, and PVL6438NS controllers are part of the Spyder family. The eight controllers are Free Topology Transceiver (FTT) LONMARK®-compliant devices designed to control HVAC equipment. These controllers provide many options and advanced system features that allow state-of-the-art commercial building control. Each controller is programmable and configurable using the NIAGARA FRAMEWORK® software.

The controllers are for use in VAV (Variable Air Volume) and Unitary HVAC control applications. Each controller contains a host microcontroller to run the main HVAC application and a second microcontroller for LONWORKS® network communications. Each controller provides flexible, universal inputs for external sensors, digital inputs, and a combination of analog outputs and digital Triac outputs.

The photo above is of the PUL6438S.

FEATURES

- Uses the Echelon® LONWORKS® network protocol.
- Free Topology Transceiver (FTT) high-speed 78 kilobit communications network.
- Capable of stand-alone operation, but can also use LONWORKS® Bus network communications.
- Sylok™ bus for use with Sylok-enabled sensors.
- 120 controllers per Q7751A,B Router when configured as a repeater.
- Field configurable and programmable for control, input, and output functions using the NIAGARA FRAMEWORK® software.
- User-defined network variables.
- Function Block engine, which allows the application designer to program the controller to perform a wide variety of HVAC applications.
- Significant Event Notification, Periodic Update capability, and Failure Detect (FD) when network inputs fail to be detected within their configurable time frame.
- Built-in Zone Control functions include a remote wall module interface and a scheduler.
- Pressure-independent or pressure-dependent single or dual duct Variable Air Volume (VAV) control as well as Unitary equipment control.
- Microbridge air flow sensor with dual integral restrictor design (PVL0000AS, PVL4022AS, PVL4024NS, PVL6436AS, and PVL6438NS only).
- Easy user access to air flow sensor inputs.
- Actuator (PVL0000AS, PVL4022AS, and PVL6436AS only) mounts directly onto VAV box damper shaft and has up to 44 lb-in. (5 Nm) torque, 90-degree stroke, and 90 second timing at 60 Hz.
- All wiring connections are made to removable terminal blocks to simplify controller installation and replacement.
- Both controller housing and actuator are UL plenum rated.



DESCRIPTION

The programmable VAV/Unitary controllers are available in eight models, as described in Table 1.

Table 1. Controller Configurations.

Controller Model	Programmable Type	Universal Inputs (UI)	Digital Inputs (DI)	Analog Outputs (AO)	Digital Outputs (DO)	Velocity Pressure Sensor (Microbridge)	Series 60 Floating Actuator
PUL1012S	Unitary	1 ^a	0	1	2	NO	NO
PUL4024S	Unitary	4 ^a	0	2	4	NO	NO
PUL6438S	Unitary	6	4	3	8	NO	NO
PVL0000AS	VAV	0	0	0	0	YES	YES
PVL4022AS	VAV	4 ^a	0	2	2	YES	YES
PVL4024NS	VAV	4 ^a	0	2	4	YES	NO
PVL6436AS	VAV	6	4	3	6	YES	YES
PVL6438NS	VAV	6	4	3	8	YES	NO

^a One Universal Input (UI-1*) is user selectable as a fast digital pulse meter

Each controller is programmable because the user chooses which function blocks to use and how to connect them. It is configurable because each Function Block has user-defined behavior.

The PUL1012S, PUL4024S, and PUL6438S models are Unitary controllers, and the PVL0000AS, PVL4022AS, PVL4024NS, PVL6436AS, and PVL6438NS models are Variable Air Volume (VAV) controllers.

Unitary Equipment Control (Models PUL1012S, PUL4024S, and PUL6438S)

Unitary equipment includes natural convection units, radiant panels, unit heaters, unit ventilators, fan coil units, and heat pumps. Unitary equipment does not require a central fan. Depending on the design, unitary equipment may perform one or all of the functions of HVAC—ventilation, filtration, heating, cooling, humidification and distribution. Unitary equipment frequently requires a distribution system for steam or hot and or chilled water.

VAV Equipment Control (Models PVL0000AS, PVL4022AS, PVL4024NS, PVL6436AS, and PVL6438NS)

VAV controllers provide pressure-independent air flow control and pressure-dependent damper control. VAV systems generally provide cool air only to zones. However, each controller has additional programmable inputs and outputs that may be used to control devices, such as a fan or VAV box reheat coils. Heaters can be staged electric or modulating hot water. Supply and exhaust pressurization control are provided on a zone basis.

SPECIFICATIONS

Electrical

Rated Voltage: 20-30 Vac; 50/60 Hz

Power Consumption:

100 VA for controller and all connected loads (including the actuator on models PVL0000AS, PVL4022AS, and PVL6436AS)

Controller only Load: 20 VA maximum; models PUL1012S, PUL4024S, PUL6438S, PVL4024NS, and PVL6438NS

Controller and Actuator Load: 21 VA maximum; models PVL0000AS, PVL4022AS, and PVL6436AS.

External Sensors Power Output: 20 Vdc ±10% @ 75 mA maximum

Environmental

VAV Operating & Storage Temperature Ambient Rating (models PVL0000AS, PVL4022AS, PVL4024NS, PVL6436AS, and PVL6438NS):

Minimum 32° F (0° C); Maximum 122° F (50° C)

Unitary Operating & Storage Temperature Ambient Rating (models PUL1012S, PUL4024S, and PUL6438S):

Minimum -40° F (-40° C); Maximum 150° F (65.5° C)

Relative Humidity: 5% to 95% non-condensing

Dimensions (H/W/D)

See Fig. 1 to Fig. 4 beginning on page 6, for dimensions drawings.

Approval Bodies

UL/cUL (E87741) listed under UL916 (Standard for Open Energy Management Equipment) with plenum rating.

CSA (LR95329-3) listed.

Meets FCC Part 15, Subpart B, Class B (radiated emissions) requirements.

Meets Canadian standard C108.8 (radiated emissions).

Conforms to the following requirements per European Consortium standards:

- EN 61000-6-1; 2001 (EU Immunity).
- EN 61000-6-3; 2001 (EU Emissions)

Real Time Clock

Operating Range: 24 hour, 365 day, multi-year calendar including day of week and configuration for automatic day-light savings time adjustment to occur at 2:00 a.m. local time on configured start and stop dates

Power Failure Backup: 24 hours at 32 to 122° F (0 to 50° C)

Accuracy: ±1 minute per month at 77° F (25° C)

Velocity Pressure Sensor (Models PVL0000AS, PVL4022AS, PVL4024NS, PVL6436AS, and PVL6438NS only)

Operating Range: 0 to 1.5 in. H₂O (0 to 374 Pa)

Accuracy: ±2% of full scale at 32 to 122° F (0 to 50° C); ±1% of full scale at null pressure

Series 60 Floating Actuator (Models PVL0000AS, PVL4022AS, and PVL6436AS only)

Rotation Stroke: 95° ± 3° for CW or CCW opening dampers

Torque Rating: 44 lb-in. (5 Nm)

Run Time for 90° rotation: 90 seconds at 60 Hz

Inputs and Outputs

Each controller has a combination of universal inputs (UI), digital inputs (DI), analog outputs (AO), and digital Triac outputs (DO) as listed in Table 1.

Digital Input (DI) Circuits

Voltage Rating: 0 to 30 Vdc open circuit

Input Type: Dry contact to detect open and closed circuit

Operating Range: Open circuit = False; Closed circuit = True

Resistance: Open circuit > 3,000 Ohms; Closed circuit < 500 Ohms

Digital Triac Output (DO) Circuits

Voltage Rating: 20 to 30 Vac @ 50-60Hz

Current Rating: 25 mA to 500 mA continuous, 800 mA (AC rms) for 60 milliseconds

Analog Output (AO) Circuits

All three analog outputs can be individually configured for current or voltage.

ANALOG CURRENT OUTPUTS:

Current Output Range: 4.0 to 20.0 mA

Output Load Resistance: 550 Ohms maximum

ANALOG VOLTAGE OUTPUTS:

Voltage Output Range: 2.0 to 10.0 Vdc

Maximum Output Current: 10.0 mA

Analog outputs may be configured as digital outputs and operate as follows:

- False (0%) produces 0 Vdc, (0 mA)
- True (100%) produces the maximum 11 Vdc, (22 mA)

Universal Input (UI) Circuits

See Table 2 for the UI specifications

Table 2. Universal Input Circuit Specifications.

Input Type	Sensor Type	Operating Range
Room/Zone Discharge Air Temperature	20K Ohm NTC	-40° F to 199° F (-40° C to 93° C)
Outdoor Air Temperature	C7031G ^a	-40° to 120°F (-40° to 49°C)
	C7041F ^a	-40° to 250°F (-40° to 121°C)
	PT1000 (IEC751 3850)	-40° F to 199° F (-40° C to 93° C)
TR23 Setpoint Potentiometer	500 Ohm to 10,500 Ohm	-4° DDC to 4° DDC (-8° DDF to 7° DDF) or 50° F to 90° F (10° C to 32° C)
Resistive Input	Generic	100 Ohms to 100K Ohms
Voltage Input	Transducer, Controller	0–10 Vdc
Discrete Input	Dry Contact closure	OpenCircuit ≥ 3000Ohms ClosedCircuit < 3000Ohms
Pulse Input ^b	Counter/Meter	Max. frequency: 15 Hz Min. pulse width: 20 ms

^a C7031G and C7041F are recommended for use with these controllers, due to improved resolution and accuracy when compared to the PT1000.

^b One Universal Input (UI-1*) on the PUL1012S, PUL4024S, PVL4022AS, and PVL4024NS is user selectable as a fast digital pulse meter

Hardware

CPU

Each controller uses a Texas Instruments MSP430 family microprocessor. The processor contains on-chip FLASH program memory, FLASH information memory, and RAM.

Memory Capacity

Flash Memory: 116 kilobytes with 8 kilobytes available for user program. The controller is able to retain FLASH memory settings for up to ten (10) years.

RAM: 8 kilobytes

Status Information

The LED on the front of the controller provides a visual indication of the status of the device. When the controller receives power, the LED appears in one of the following allowable states, as described in Table 3.

Table 3. Status LED States.

LED State	Blink Rate	Status or Condition
OFF	not applicable	No power to processor, LED damaged, low voltage to board, or controller damaged.
ON	ON steady; not blinking	Processor and/or controller is not operating.
Very slow blink (continuous)	1 second ON, 1 second OFF	Controller is operating normally.
Slow blink (continuous)	0.5 second ON, 0.5 second OFF	Controller alarm is active, controller in process of download, or controller lost its configuration.
Medium blink (continuous)	0.25 second ON, 0.25 second OFF	Controller firmware is loading.
Fast blink (continuous)	0.10 second ON, 0.10 second OFF	Controller is in manual mode under control of the PC-based software tool.

Communications

Each controller uses an FTT transformer-coupled communications port. The controller's Manchester encoded data is presented to other controllers and devices on the LONWORKS® Bus at 78 kilobits per second (kbs) via Echelon® communication protocol. The transformer-coupled communications interface offers a much higher degree of common mode-noise rejection while assuring dc isolation. The LONWORKS® Bus is polarity insensitive, eliminating installation errors due to miswiring.

The maximum LONWORKS® Bus network length is 4,600 ft. (1,400 m). For LONWORKS® Bus network lengths greater than the above, see "LONWORKS® Bus Wiring Guidelines," form no. 74-2865.

The theoretical limit for each LONWORKS® Bus segment is 60 controllers. Up to 120 controllers can be configured when the Q7751A,B Router (configured as a repeater) is used, and the bus must be either singly or doubly terminated. Actual installations may have a lower limit, depending on the devices connected.

Honeywell-provided cable types for LONWORKS® Bus communications wiring are Level IV 22 AWG (0.34 sq. mm) plenum or non-plenum rated unshielded, twisted pair, stranded conductor wire.

- For non-plenum areas, U.S. part AK3798 (single-pair stranded) can be used.

- For plenum areas, U.S. part AK3797 (single-pair stranded) or U.S. part AK3799 (two-pair stranded) can be used.

Contact Echelon Corp. Technical Support for the recommended vendors of Echelon approved cables.

Refer to the "LONWORKS® Bus Wiring Guidelines," form 74-2865, for a complete description of LONWORKS® Bus network topology rules and approved cable types.

If a longer LONWORKS® Bus network is required, the Q7751A,B Router (configured as a repeater) can be added to extend the length of the LONWORKS® Bus. Each network segment can have a maximum of one repeater.

NOTE: Connection for operator access to the LONWORKS® Bus is provided by plugging the Serial LONTALK® Adapter (SLTA) connector into the LONWORKS® Bus jack on the controller.

Sylk™ Bus

Sylk is a two wire, polarity insensitive bus that provides both 18 Vdc power and communications between a Sylk-enabled sensor and a Sylk-enabled controller. Using Sylk-enabled sensors saves I/O on the controller and is faster and cheaper to install since only two wires are needed and the bus is polarity insensitive. Sylk sensors are configured using the latest release of the Spyder® Tool for WEBPro and WEBStation.

Network Variables Profile

Network variables, as described in Table 4 on page 5, are communicated over the LONWORKS® Bus. User-defined variables provide for customized configurations. The controller's built-in functions provide for the selection of variables, which are available from/to the network. Each network variable is named and configured using the NIAGARA FRAMEWORK® software.

Each controller supports a range of network variables, depending on the byte count (storage requirements) of each variable. In most typical installations, a maximum of 30–37 variables are configured.

NOTE: The maximum number of variables that a controller supports is 62, and the maximum byte count per variable is 31.

The controller is capable of supporting up to 1,922 separate data values.

In Table 4 on page 5, the network variable prefixes have the following meaning:

- nvi — Network Variable Input
- nvo — Network Variable Output
- nci — Configuration Property Network Variable Input stored in Non-Volatile Memory
- nro — Network Variable Output stored in Non-Volatile memory

Table 4. Network Object Variables List.

Network Object Variables		
→ Input	Mandatory	Output →
nviNodeRequest * ^a		nvoNodeStatus *
→ Input	Optional	Output →
nviTimeSet *		nvoFileStatus *
nviFileRequest		
nviFilePos *		
→ Input	Manufacturer Defined	Output →
nviDebugIndx *		nvoTime *
nviInUse *		nvoConfigError *
nviManVal *		nvoDebug1 *
		nvoDebug2 *
		nvoAlarmH *
		nvoAlarmStatus *
		nvoError *
		nvoIO1 *
		nvoIO2 *
		nvoIO3 *
→ Input	Configuration (Manufacturer Defined)	Output →
nciApplVerNew *		nroPgmVer *
nciDeviceName *		
nciSendHrtBt *		
nciRcvHrtBt *		
nciUICalOffset *		
→ Input	User-defined (Examples of) ^b	Output →
nviSpaceTemp		nvoSpaceTemp
nviSetPoint		nvoEffectSetPt
nviManOverride		nvoUnitStatus
nviEmergCmd		nvoTerminalLoad
nviEnergyHoldOff		nvoEnergyHoldOff
nviFanSpeed		nvoBoxFlow

^a Network variables marked with an asterisk (*) are fixed. All network variables, other than those that are user-defined, are fixed and not configurable.

^b User-defined network variables are created using the NIAGARA FRAMEWORK® software. The variables listed in the table are a few examples. A wide range of variables are user-definable.

Accessories

- 201052A,B,C Auxiliary Switches (one, two or three switches)
- 205979 Connector Cable from the Q7752A Serial Interface Adapter to Controller or Wall Module
- 209541B Termination Module

- C7041B,C,D,P,R Air Temperature Sensor (indoor)
- C7770A Air Temperature Sensor (indoor/plenum)
- C7031G Air Temperature Sensor (outdoor)
- C7041F Air Temperature Sensor (outdoor)
- Q7751A,B Router (configured as a repeater)
- Q7752A,B Serial Interface Adapter
- TR23 Wall Module
- C7400A Enthalpy Sensor
- P7640 Pressure Transducer Family
- C7232 CO₂ Sensor Family
- C7600 Humidity Sensor Family
- H7625, H7635, and H7655 Humidity and Temperature Sensors

Refer to the “Sensors Product Overview,” form 63-9285, for additional accessories.

Mounting

The controller enclosure is constructed of a plastic base plate and a plastic factory-snap-on cover. The cover does not need to be removed from the base plate for either mounting or wiring. Removable terminal blocks are used for all wiring connections, which allow the controller to be wired before or after mounting.

The controller can be mounted in any orientation. Ventilation openings are designed into the cover to allow proper heat dissipation regardless of the mounting orientation.

NOTE: The controller must be mounted in a position that allows clearance for wiring, servicing, removal, connection of the LONWORKS® Bus Jack, and access to the NEURON® Service Pin.

NOTE: For complete mounting information, refer to the “Installation Instructions,” form 62-0287.

PVL0000AS, PVL4022AS, and PVL6436AS Mounting

The PVL0000AS, PVL4022AS, and PVL6436AS controllers include the direct-coupled actuator with Declutch mechanism, which is shipped hard-wired to the controller.

The actuator mounts directly onto the VAV box damper shaft and has up to 44 lb-in. (5 Nm) torque, 90-degree stroke, and 90 second timing at 60 Hz. The actuator is suitable for mounting onto a 3/8 to 1/2 in. (10 to 13 mm) square or round VAV box damper shaft. The minimum VAV box damper shaft length is 1-9/16 in. (40 mm).

After the actuator is mounted onto the damper shaft, the controller mounts to a panel by using four No. 6 or No. 8 machine or sheet metal screws inserted through the corners of the base plate.

PUL1012S, PUL4024S, PUL6438S, PVL4024NS, and PVL6438NS Mounting

These controllers mount to either a panel or DIN rail (standard EN50022; 7.5 mm x 35 mm).

- For panel mounting, use four No. 6 or No. 8 machine or sheet metal screws inserted through the corners of the base plate.
- For DIN rail mounting, refer to the “Installation Instructions,” form 62-0287.

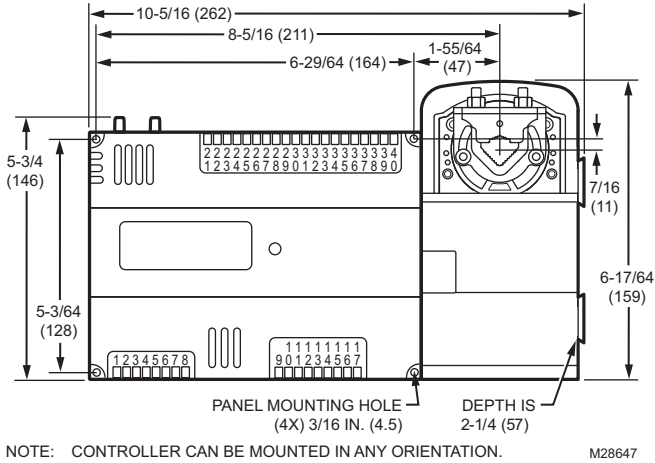

NOTE: CONTROLLER CAN BE MOUNTED IN ANY ORIENTATION. M28647

Fig. 1. Panel mounting — controller and actuator dimensions in inches (mm) for model PVL6436AS only.

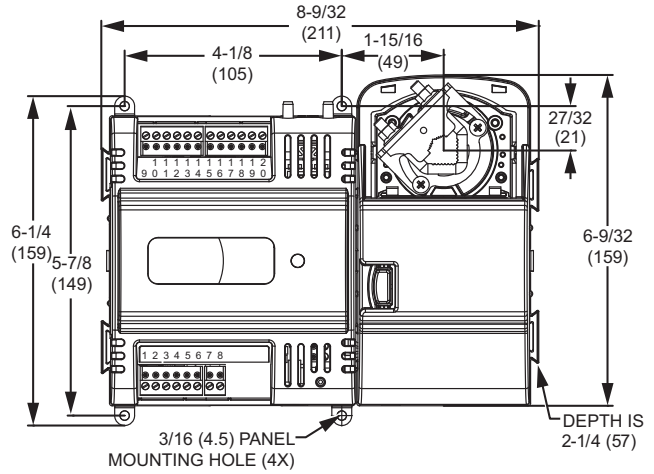

NOTE: CONTROLLER CAN BE MOUNTED IN ANY ORIENTATION. M28648

Fig. 2. Panel mounting — controller and actuator dimensions in inches (mm) for PVL0000AS and PVL4022AS only (PVL4022AS shown).

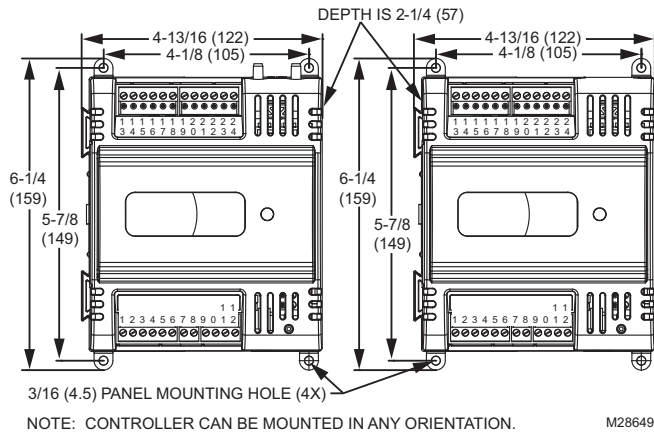

NOTE: CONTROLLER CAN BE MOUNTED IN ANY ORIENTATION. M28649

Fig. 3. Panel mounting — controller dimensions in inches (mm) for PUL1012S, PUL4024S, and PVL4024NS only (PUL4024S and PVL4024NS shown).

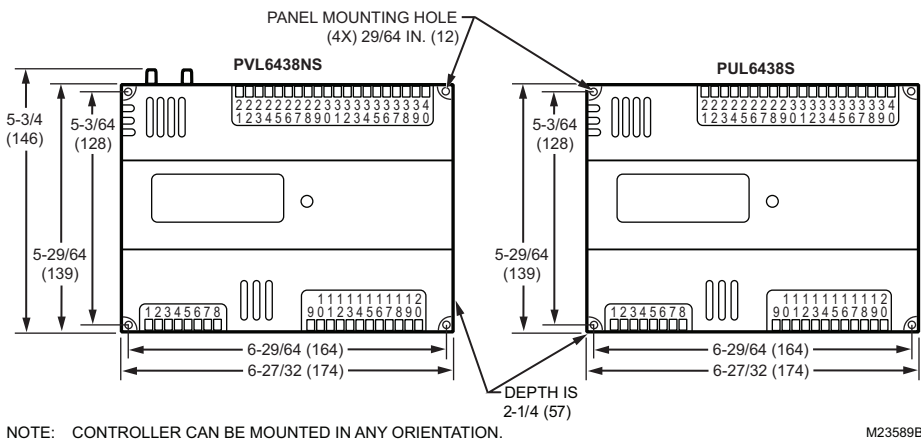

NOTE: CONTROLLER CAN BE MOUNTED IN ANY ORIENTATION. M23589B

Fig. 4. Panel mounting — controller dimensions in inches (mm) for models PVL6438NS and PUL6438S.

LON®, LONTALK®, LONWORKS®, and NEURON® are registered trademarks of Echelon® Corporation.

LONMARK® and the LonMark Logo are trademarks of the LonMark Association.

NIAGARA FRAMEWORK® and the Niagara framework logo are registered trademarks of Tridium, Inc.

Automation and Control Solutions

Honeywell International Inc.
1985 Douglas Drive North
Golden Valley, MN 55422
customer.honeywell.com

Honeywell Limited-Honeywell Limitée
35 Dynamic Drive
Toronto, Ontario M1V 4Z9

