

IGNITION AND DETECTION ELECTRODES WITH INBUILT RESISTOR

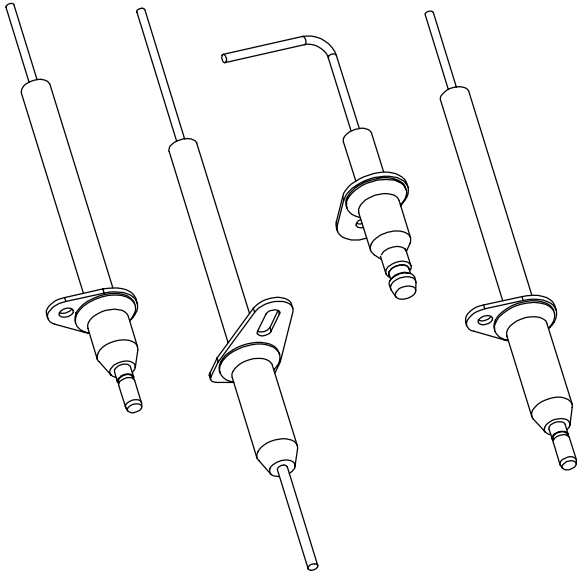

Application

The type and features of the material used to manufacture these electrodes make them suitable not only as ignition electrodes, but also as flame sensors in gas burners. Thanks to the possibility to fit a resistor inside the electrodes to reduce the emission of electromagnetic interference upon generation of the electrical spark, these electrodes are particularly useful when fitted in devices which have to meet the electromagnetic compatibility requirements of the Directive 89/336/EEC. In addition, they are the perfect solution for the manufacture of devices fitted with "single electrode" ignition and flame monitoring systems.

These sensors are the most used flame detectors for gas burners; they exploit the electric conductivity of the flame and profit by the fact that a substantial difference between the mass of the electrode in contact with the flame and the mass of the burner allows current flow almost exclusively from the electrode to the burner metal housing.

The generated current value, usually amounting to some μA , depends on the relation between the mass of the electrode and the mass of the burner, on the position of the electrode towards the flame and on the combustion quality.

Warning: make sure that the detection electrode is sufficiently far from the ignition electrode, in order to prevent the electric discharges produced during the burner ignition from striking the ground through the detection electrode, thus damaging the connected flame detection device.

Features

Electrodes consist of a kanthal rod, an insulating glazed alumina ceramic part and a galvanized iron fixing bracket; whereas the back side, made of thermoplastic material resisting to high temperature, is press-forged so as to be fitted to house the radio interference attenuation resistor.

The electrical connection is carried out by means of 4 or 6 mm fast-on terminals or by a high isolation teflon cable.

The electrode back working through press-forging enables to achieve extremely interesting advantages, such as:

- attenuation resistor between rod and terminal, provided with enough strength to stand the stress generated by spark energy and with very reduced dimensions;
- high torque and bending strength of both rod and bracket;
- high impact and vibration strength.

Ceramic

glazed alumina diameter	7 mm
bracket length (C)	17/27/62 mm

Bracket

galvanized iron

Rod

kanthal diameter	2 mm
standard length out of ceramic (L)	50 mm

Connection terminals

cylindrical diameter	4 o 6.3 mm
teflon cable diameter	3 mm
<i>standard length</i>	300 mm
<i>electrical insulation</i>	24 kV

Resistor

wire-wound power dissipation	1 W
ohmic values	from 1 to 2.7k Ω

Thermoplastic material

Stanyl TE250F9BK V0 F.V. 45%

Dimensions

Fig. 1-2-3 show the main electrode dimensions.
 Fig. 4 shows the dimensions of the available brackets.

Fig. 1 Electrode with cylindrical connector without resistor

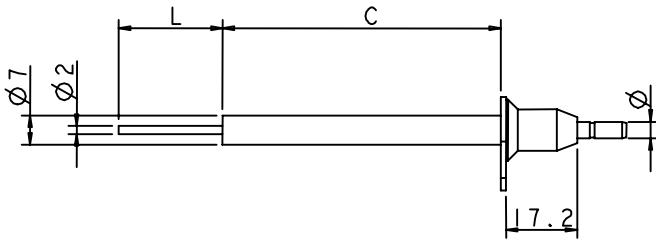
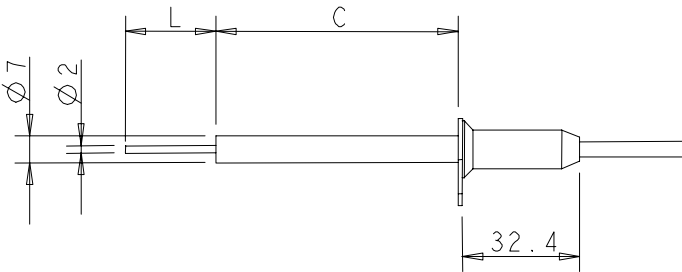

Fig. 2 Electrode with cylindrical connector and resistor



Fig. 3 Electrode with teflon cable and resistor



Ceramic length from the bracket $C = 17; 27; 62$ mm
 Rod length $L = 50$ mm standard
 Connection terminal diameter $\phi = 4$ or 6 mm

Electrodes with various ceramic, rod and cable lengths or with different resistor values are available on request.

Fig. 4 Standard bracket and bracket with button-hole

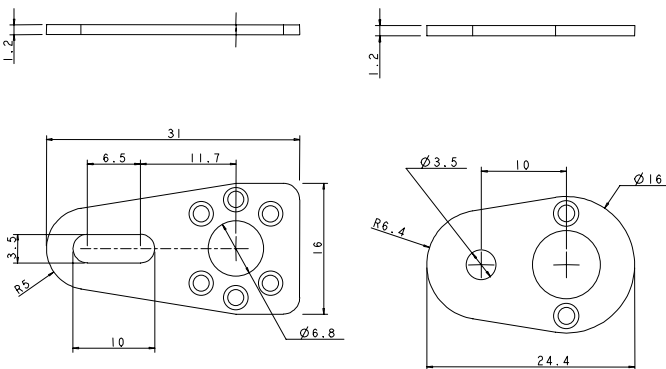

Accessories

For electrodes provided with cylindrical terminal, we can supply connectors (see Fig. 5) to be fitted to cables with silicone rubber sheath with suitable diameter (see Fig. 7). For the electrical insulation of the terminals, we can supply nylon (PTA) or silicone rubber protections (see Fig. 6).

Fig. 5 Terminals diameter 4 and diameter 6.35 mm

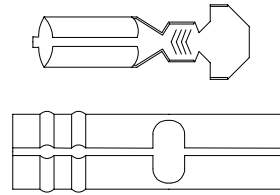

Fig. 6 PTA protection and silicone rubber protection

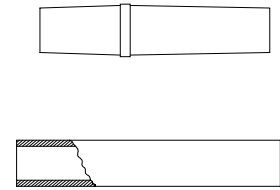
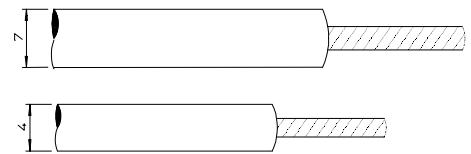

Fig. 7 CH4 and CH6 high voltage cables



BRAHMA S.p.A.
 Via del Pontiere, 31
 37045 Legnago (VR)
 Tel. +39 0442 635211 - Telefax +39 0442 25683 - 635256
<http://www.brahma.it>
 E-mail : brahma@brahma.it

00/02/18 Subject to amendments without notice