

## N20, N34 Series MN7220, MN7234

NON-SPRING RETURN DAMPER ACTUATOR

20/34 Nm (175/300 lb-in) FOR MODULATING CONTROL

### PRODUCT DATA



### GENERAL

These direct-coupled damper actuators provide modulating control for:

- rotary valves,
- air handling units,
- ventilation flaps,
- louvers, and
- reliable control for air damper applications with up to 50 sq.ft. (20 Nm / 175 lb-in) or 85 sq. ft. (34 Nm / 300 lb-in) (seal-less damper blades; air friction-dependent).

### FEATURES

- **New self-centering shaft adapter**
- **Access cover to facilitate connectivity**
- **Declutch for manual adjustment**
- **Mechanical end limits (MN7220 only)**
- **Field-installable auxiliary switches**
- **Rotation direction selectable by switch**
- **Mountable in any orientation (no IP54 if upside down)**
- **Mechanical position indicator**

### SPECIFICATIONS

<b>Supply voltage</b>	24 Vac $\pm 20\%$ , 50/60 Hz; 24 Vdc -10...+20%
<b>Nominal voltage</b>	24 Vac, 50/60 Hz; 24 Vdc
<i>All values stated hereinafter apply to operation under nominal voltage conditions.</i>	
<b>Power consumption</b>	
MN7220	6 VA / 6 W
MN7234	8 VA / 6 W
<b>Ambient limits</b>	
Ambient operating limits	-5...+140 °F (-20...+60 °C)
Ambient storage limits	-40...+175 °F (-40...+80 °C)
Relative humidity	5...95%, non-condensing
<b>Safety</b>	
Protection standard	IP54 (non-USA models) NEMA2 (USA models)
Protection class	II as per EN 60730-1
Overvoltage category	II
<b>Lifetime</b>	
Full strokes	60000
Repositions	1.5 million
<b>Mounting</b>	
Round damper shaft	3/8...1-1/16" (10...27 mm)
Square damper shaft	3/8...11/16" (10...18 mm); 45° steps
Shaft length	min. 7/8" (22 mm)
<b>Control signal</b>	0(2)...10 Vdc 0(4)...20 mA
Input impedance	100 k $\Omega$ [0...10 V] 500 $\Omega$ m [0...20 mA]
<b>Feedback signal</b>	
Limits	$\pm 1$ mA at 0...10 V
<b>Auxiliary switch (when included)</b>	
Rating	5 A (resistive) / 3 A (inductive)
Triggering points	5° / 85°
<b>Torque rating</b>	
MN7220	175 lb-in (20 Nm)
MN7234	300 lb-in (34 Nm)
<b>Runtime</b>	95 sec (60 Hz) / 110 sec (50 Hz)
<b>Rotation stroke</b>	95° $\pm$ 3°
<b>Dimensions</b>	see "Dimensions" on page 8
<b>Weight</b>	3 lbs. (1.35 kg)
<b>Noise rating</b>	40 dB(A) max. at 1 m



## MODELS

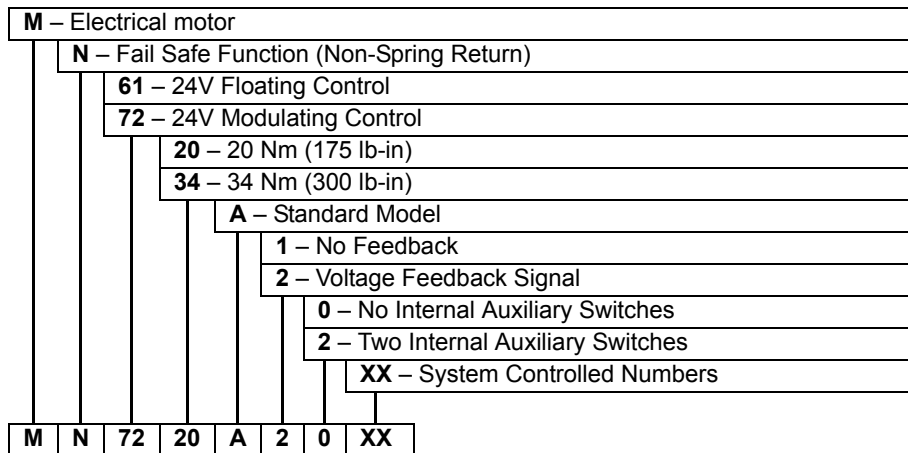

Fig. 1. Product Identification System

## OPERATION/FUNCTIONS

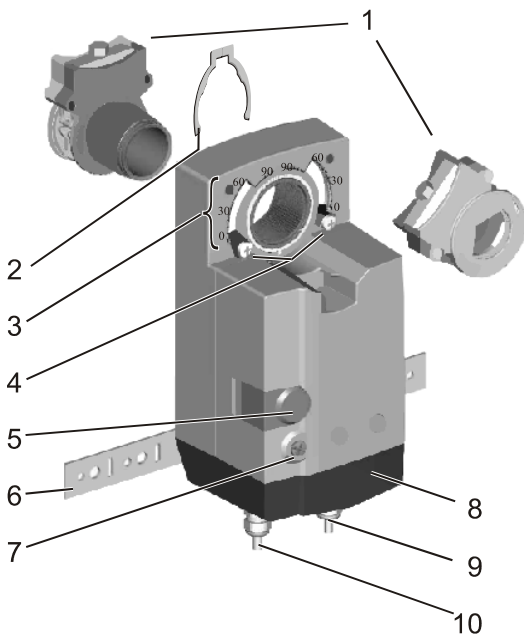

Fig. 2. Setting units and control elements

### Legend for Fig. 2. Setting units and control elements:

1. Self-centering shaft adapter
2. Retainer clip
3. Rotational angle scales (0...90° / 90...0°)
4. Mechanical end limits (20 Nm [175 lb-in] models, only)
5. Declutch button
6. Anti-rotation bracket
7. Rotation direction switch
8. Access cover
9. Internal auxiliary switch wire
10. Power and control wire

### Contents of Package

The delivery package includes the actuator itself, parts 1 through 10 (see Fig. 2; in the case of U.S. models – e.g. MN7220 – parts 1 through 8), the anti-rotation bracket screws, and the SM mounting plate and screws.

### Modulating Control

The actuator is capable of being operated by several controllers providing Vdc or mA output.

## ORDERING INFORMATION

When purchasing replacement and modernization products from your TRADELINE® wholesaler or distributor, refer to the TRADELINE® Catalog or price sheets for complete ordering number.

If you have additional questions, need further information, or would like to comment on our products or services, please write or phone:

1. Your local Honeywell Automation and Control Products Sales Office (check white pages of your phone directory).
2. Honeywell Customer Care  
1885 Douglas Drive North  
Minneapolis, Minnesota 55422-4386

In Canada—Honeywell Limited/Honeywell Limitée, 35 Dynamic Drive, Scarborough, Ontario M1V 4Z9.

International Sales and Service Offices in all principal cities of the world. Manufacturing in Australia, Canada, Finland, France, Germany, Japan, Mexico, Netherlands, Spain, Taiwan, United Kingdom, U.S.A.

## Rotary Movement

The control signal and the corresponding rotation direction (clockwise or counterclockwise) can be selected using the rotation direction switch (see part Rotation direction switch in Fig. 2), thus eliminating the need to re-wire. To ensure tight closing of the dampers, the actuator has a total rotation stroke of 95°.

As soon as operating power is applied, the actuator may start to run. When power is removed, the actuator remains in position. For actuator-controller wiring instructions, see section "Wiring" on page 5.

## Rotation Direction Switch

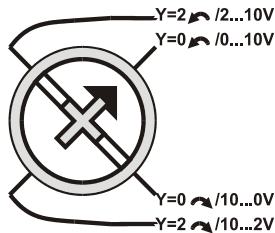

Fig. 3. Rotation Direction Switch

Table 1. Feedback/control signal values

Rotation direction switch position	Feedback/control signal when actuator is	
	totally ↶	totally ↷
Y=2 ↷ / 2...10V	U = 2 V	U = 10 V
Y=0 ↶ / 0...10V*	U = 0 V	U = 10 V
Y=0 ↶ / 10...0V	U = 10 V	U = 0 V
Y=2 ↷ / 10...2V	U = 10 V	U = 2 V

\* Default shipping position.

## Feedback Signal and Manual Adjustment

If, while the actuator is not rotating, the user declutches it and manually repositions the shaft adapter, the feedback signal will then follow the new position at which the shaft adapter has been left.

## Power Off/On Behavior

In case the power to the actuator fails, after re-applying power, the actuator acknowledges its present position and follows the signal from the controller. This makes it unnecessary for the actuator to employ autoadaptation in order to re-map the control signal settings.

## Dip Switches

The actuators are equipped with two dip switches accessible after removing the access cover (see Fig. 4).

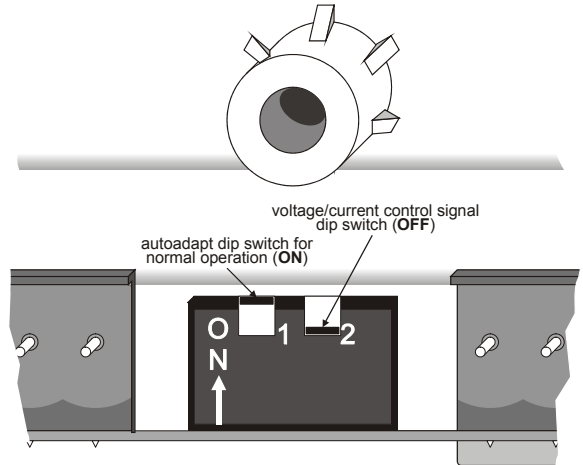

Fig. 4. Dip switches (view with PCB at bottom)

## Autoadapt Dip Switch for Normal Operation

In its default shipping position, the autoadapt dip switch for normal operation is set to ON as shown in Fig. 4. Dip switches (view with PCB at bottom)4. If it is set to OFF, no autoadaptation is performed, and the control signal map remains constant.

The autoadapt functionality does not have to be triggered. Rather, the SmartAct actuator does this automatically when the min. and max. control signals are provided (see Fig. 5); the feedback signal is likewise autoadapted.

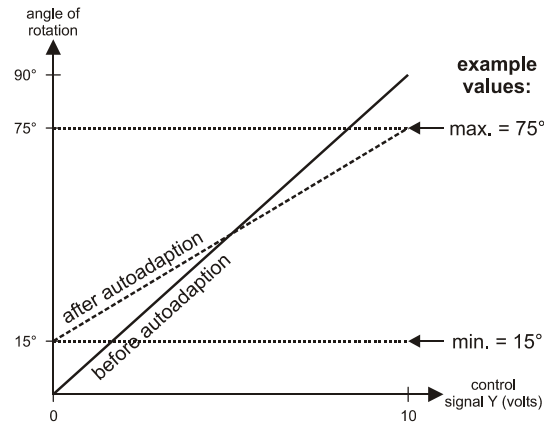

Fig. 5. Actuator positioning curve

In order to make use of the autoadapt functionality, proceed as follows:

1. Set the autoadapt dip switch to the ON position.
2. If necessary, limit the stroke to the desired range using the mechanical end limits.
3. Drive the actuator to the left end limit (totally counterclockwise) by setting the control signal as specified in Table 1. Feedback/control signal values1.
4. Drive the actuator to the right end limit (totally clockwise) by setting the control signal as specified in Table 1. Feedback/control signal values1. The stroke has now been limited to 0...100% of the control signal range.

### Voltage/Current Control Signal Selection Dip Switch

In its default shipping position, the voltage/current control signal dip switch (see Fig. 4) is set to OFF (= voltage control). as shown in Fig. 4. Setting it to ON results in current control.

### Position Indication

The hub adapter indicates the rotation angle position by means of the rotational angle scales (0...90° / 90...0°).

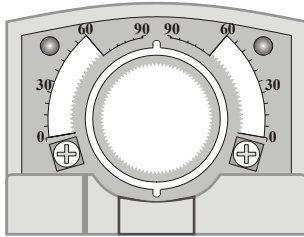

Fig. 6. Position indication

### Manual Adjustment

**IMPORTANT**

*In order to prevent equipment damage, you must remove power before manual adjustment.*

After removing power, the gear train can be disengaged using the declutch button, permitting the actuator shaft to be manually rotated to any position. The feedback signal will then follow the new position.

### Limitation of Rotation Stroke

Two mechanical end limits (adjustable in 3° increments) are provided (20 Nm [175 lb-in] models, only) to limit the angle of rotation as desired (see Fig. 7).

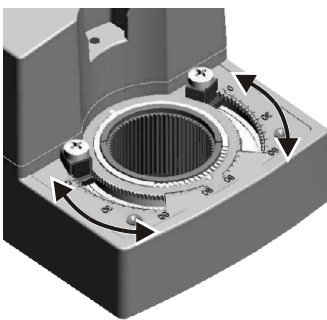

Fig. 7. Mechanical end limits

The mechanical end limits must be securely fastened in place as shown in Fig. 8. Correct / incorrect tightening of end limits8. Specifically, it is important that they properly mesh with the rotational angle scales when the screws are tightened.

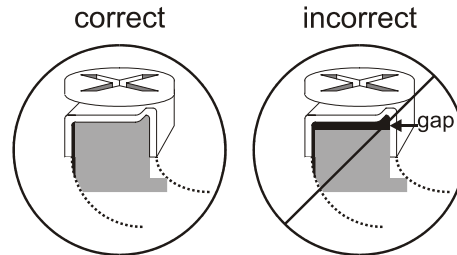

Fig. 8. Correct/incorrect tightening of end limits

### Internal Auxiliary Switches

The internal auxiliary switches are set to change from “common” to “normally open” at angles of 5° and 85°, respectively, from the totally counterclockwise position.

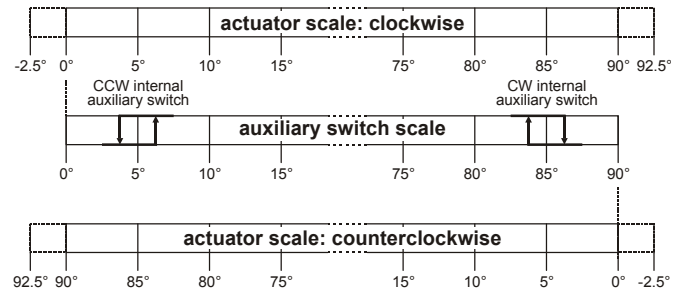

Fig. 9. Internal auxiliary switches

### Override

If terminal 3 of the terminal strip (see section “Wiring Diagrams” on page 6) is unplugged, the stroke will be 0%; reversing the rotation direction using the rotation direction switch will result in a max. stroke of 100%. If terminal 3 is jumped with terminal 1 (24 V), the stroke will be 50%.

## INSTALLATION

These actuators are designed for single-point mounting.

**IMPORTANT**

*In order to prevent equipment damage, you must remove power or set the rotation direction switch to the “Service/Off” position before manual operation.*

### Mounting Instructions

All information and steps are included in the Installation Instructions supplied with the actuator.

## Mounting Position

The actuators can be mounted in any desired orientation (no NEMA2 or IP54 if mounted upside down; see Fig. 10). Choose an orientation permitting easy access to the actuator's cables and controls.

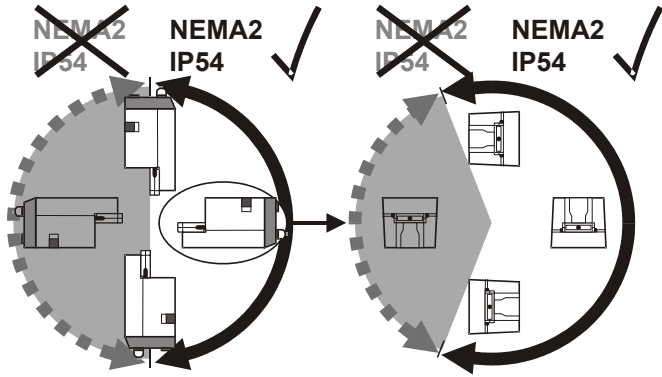

Fig. 10. Mounting for IP54/NEMA2

## Mounting Bracket and Screws

If the actuator is to be mounted directly on a damper shaft, use the mounting bracket and screws included in the delivery package.

## Self-Centering Shaft Adapter

The self-centering shaft adapter can be used for shafts having various diameters (3/8...1-1/16" [10...27 mm]) and shapes (square or round).

In the case of short shafts, the shaft adapter may be reversed and mounted on the duct side.

## Stroke Limitation with Mechanical End Limits

The mechanical end limits (20 Nm [175 lb-in] models, only) enable the stroke to be limited from 0...90° in increments of 3°.

## Wiring

### Access cover

To facilitate wiring the actuator to the controller, the access cover can be detached from the actuator.

### IMPORTANT

*Remove power before detaching the access cover. Once the access cover has been removed, please take care to avoid damaging any of the parts now accessible.*



Fig. 11. Access cover

Depending upon the model, the access cover may have one or two terminal strips, including a layout with a description for each of the terminals.

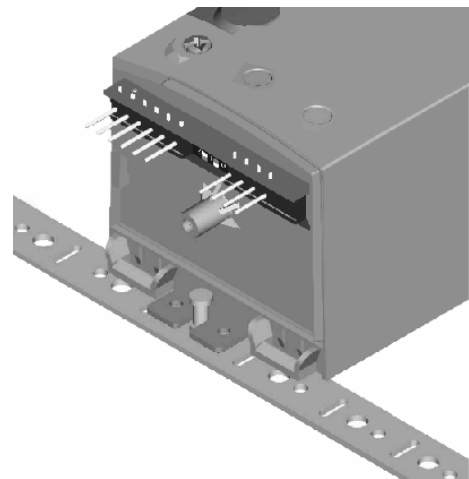
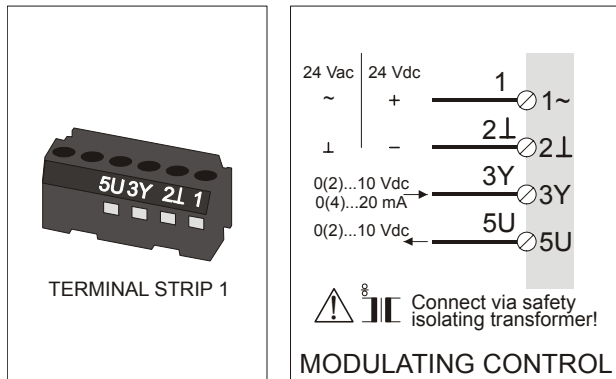

Fig. 12. Actuator with access cover removed

## Wiring Diagrams

### MN7220/MN7234



### MN7220 WITH SWITCHES

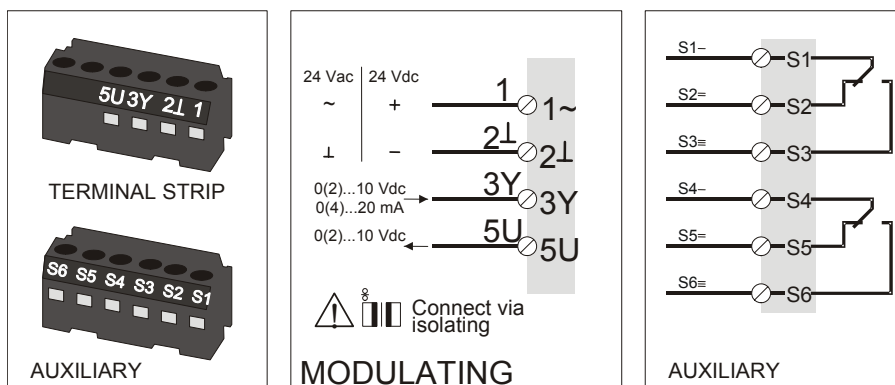

NOTE: Internal auxiliary switches S1 and S4 must be connected to the same power source.

connecting cable	terminal	name	
supply and signal lines	1~	24 Vac~ / 24 Vdc+	
	2⊥	24 Vac⊥ / 24 Vdc-	
	3Y	0(2)...10 Vdc / 0(4)...20 mA control signal	
	5U	0(2)...10 V feedback signal	
auxiliary switched (when included)	CCW (left) 5°	S1	Common
		S2	normally closed
		S3	normally open
	CW (right) 85°	S4	Common
		S5	normally closed
		S6	normally open



# DIMENSIONS

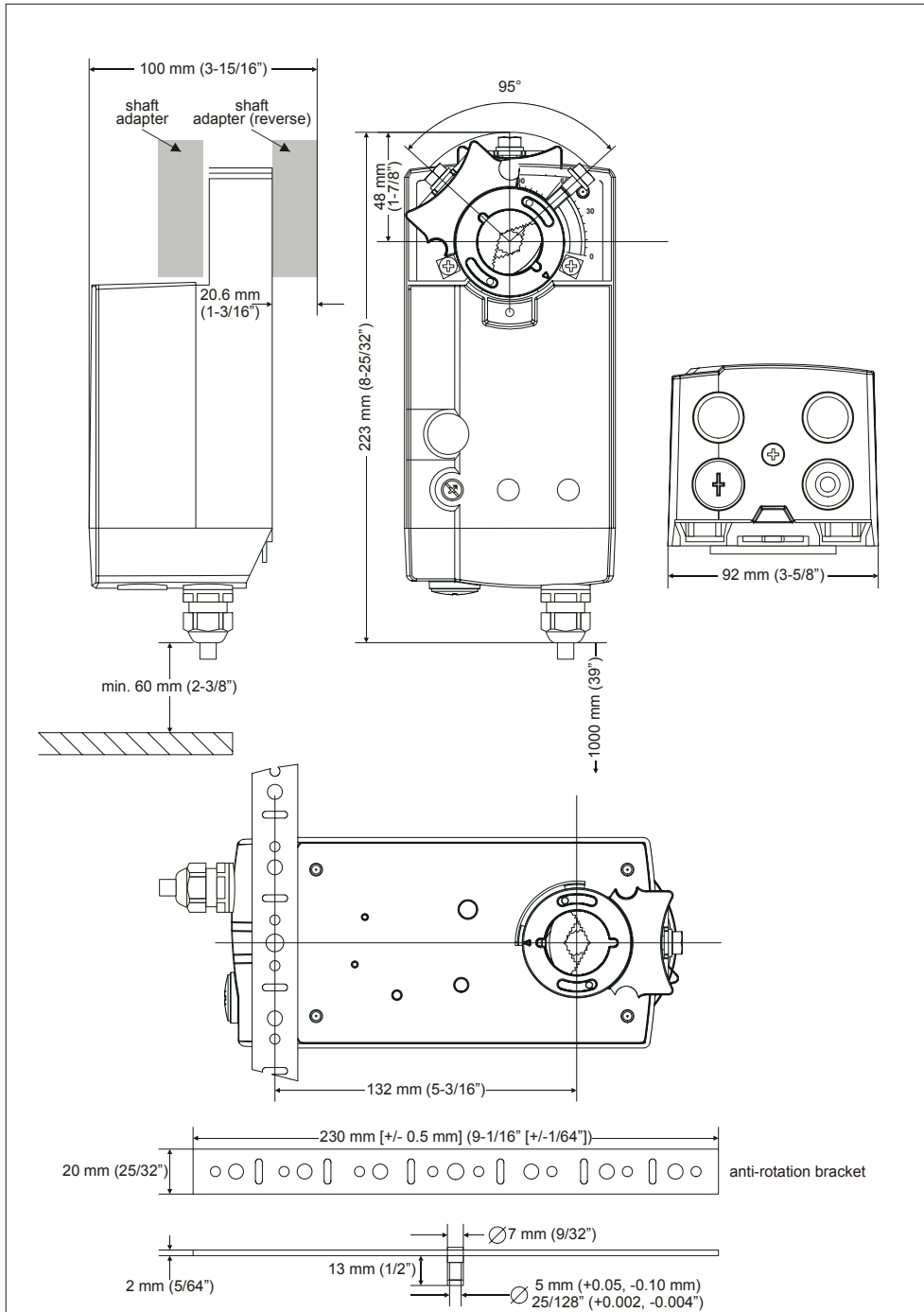

## Automation and Control Solutions

Honeywell International Inc.  
 1985 Douglas Drive North  
 Golden Valley, MN 55422  
 customer.honeywell.com

Honeywell Limited-Honeywell Limitée  
 35 Dynamic Drive  
 Scarborough, Ontario M1V 4Z9

® U.S. Registered Trademark  
 © 2005 Honeywell International Inc.  
 63-2587—1 M.S. Rev. 10-05

# Honeywell



Printed in U.S.A. on recycled paper containing at least 10% post-consumer paper fibers.