

V5011N Two-Way Threaded Globe Valve

PRODUCT DATA

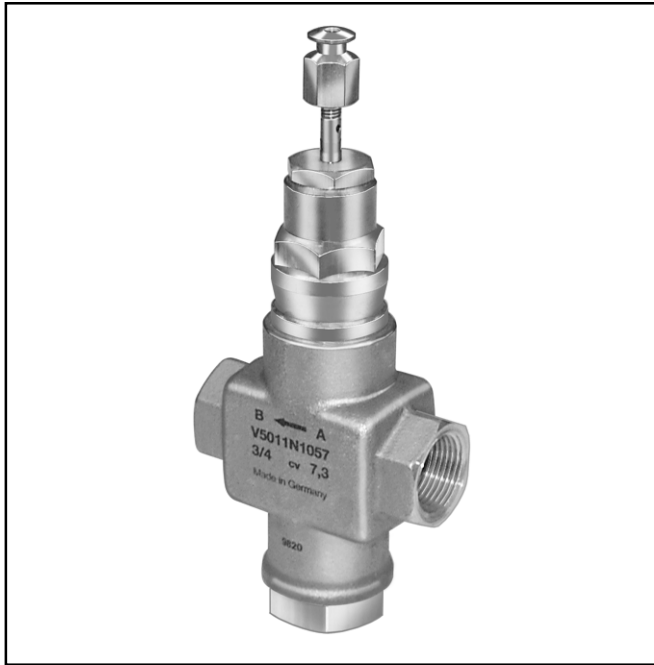

FEATURES

- Red brass body with NPT-threaded end connections.
- Low seat leakage rate (≤ 0.05 percent C_v).
- 50:1 rangeability per VDI/VDE 2173.
- Spring-loaded, self-adjusting packing.
- Accurate positioning to ensure state of the art temperature control.
- Directly coupled electric and pneumatic actuators for easy mounting.
- Sizes range from 1/2 inch to 2 inches.
- Valve designs provide equal percentage flow characteristic for water and linear flow characteristic for steam.
- Stainless steel stem and metal-to-metal seats.
- Repack and rebuild kits for field servicing.

APPLICATION

The V5011N is a two-way threaded globe valve that controls steam, water, and glycol solutions (up to 50 percent concentration) in heating or cooling HVAC applications. The valve is used in two-position and modulating control systems. The valve is not suitable for combustible gas service.

Contents

Application	1
Features	1
Specifications	2
Ordering Information	2
Installation	10
Checkout	11



SPECIFICATIONS

IMPORTANT

The specifications given in this publication do not include normal manufacturing tolerances. Therefore, an individual unit may not exactly match the listed specifications. Also, this product is tested and calibrated under closely controlled conditions and some minor differences in performance can be expected if those conditions are changed.

Models:

V5011N Valve: Two-way threaded globe valve for steam, water, or glycol. NPT-threaded pipe connections. Throttling plug provides equal percentage characteristic of flow for water (V5011N1xxx, V5011N3xxx), linear characteristic of flow for steam (V5011N2xxx). V5011N1xxx and V5011N2xxx are direct acting (stem down to close) V5011N3xxx is reverse acting (stem up to close).

Valve Sizes and Flow Capacities:

See Table 1.

Table 1. Valve size and flow capacities.

Valve Body Pipe Size (in.)	Flow Capacity (C _v)
1/2	0.73
1/2	1.16
1/2	1.85
1/2	2.9
1/2	4.7
3/4	7.3
1	11.7
1-1/4	18.7
1-1/2	29.3
2	46.8

Pipe Connections:

Female NPT-threaded connections.

Seat:

Stainless steel, replaceable (except V5011N3xxx 3/4 in. to 1-1/4 in. which have integral brass seat).

ANSI Body Class:

150 psi.

Stem:

Stainless steel.

Plug:

Brass on V5011N1xxx and V5011N3xxx for water; stainless steel on V5011N2xxx for steam.

Stroke:

3/4 in. (20 mm).

Approximate Leakage Rate:

0.05 percent C_v.

Pattern:

2-way, straight-through.

Body Material:

Red brass.

Packing:

Spring-loaded, carbon fiber reinforced PTFE V-rings.

Pressure-Temperature Ratings:

Water: 36°F to 248°F, 227 psi.
248°F to 340°F, 211 psi.
Steam: 100 psi at 340°F.

Valve Flow Characteristics:

Water: equal percentage flow characteristic (V5011N1xxx, V5011N3xxx).
Steam: linear flow characteristic (V5011N2xxx). See Fig. 1.

Close-Off Pressure Ratings:

See Fig. 2 and Tables 2 and 3.

ORDERING INFORMATION

When purchasing replacement and modernization products from your TRADELINE® wholesaler or distributor, refer to the TRADELINE® Catalog or price sheets for complete ordering number.

If you have additional questions, need further information, or would like to comment on our products or services, please write or phone:

1. Your local Home and Building Control Sales Office (check white pages of your phone directory).
2. Home and Building Control Customer Logistics
Honeywell Inc., 1885 Douglas Drive North
Minneapolis, Minnesota 55422-4386 (612) 951-1000

In Canada—Honeywell Limited/Honeywell Limitée, 155 Gordon Baker Road, North York, Ontario M2H 3N7.

International Sales and Service Offices in all principal cities of the world. Manufacturing in Australia, Canada, Finland, France, Germany, Japan, Mexico, Netherlands, Spain, Taiwan, United Kingdom, U.S.A.

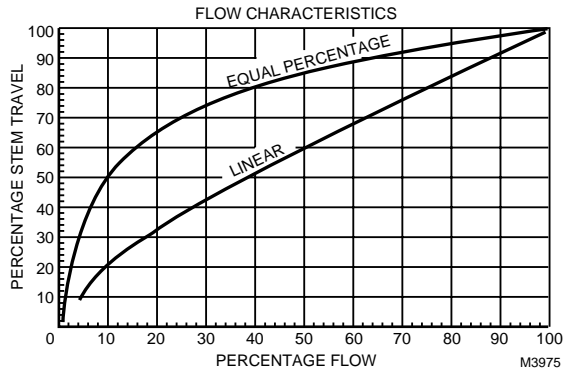

Fig. 1. Equal percentage and linear flow characteristics.

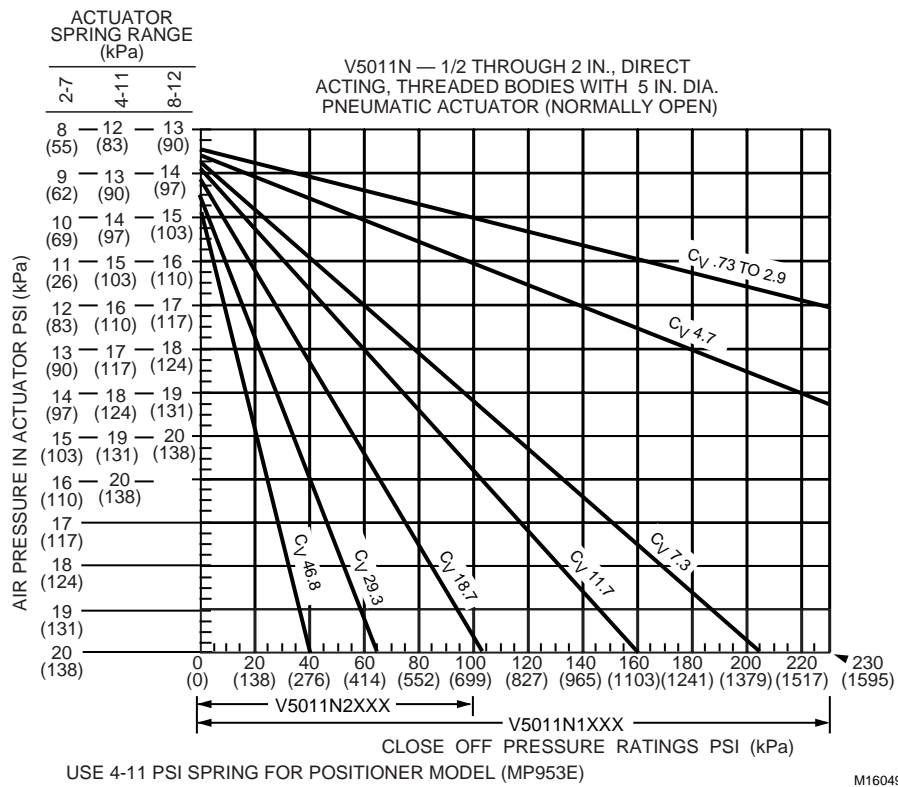

Fig. 2. Close-off pressures at various control air pressures for V5011N Valves and MP953 Pneumatic Actuators.

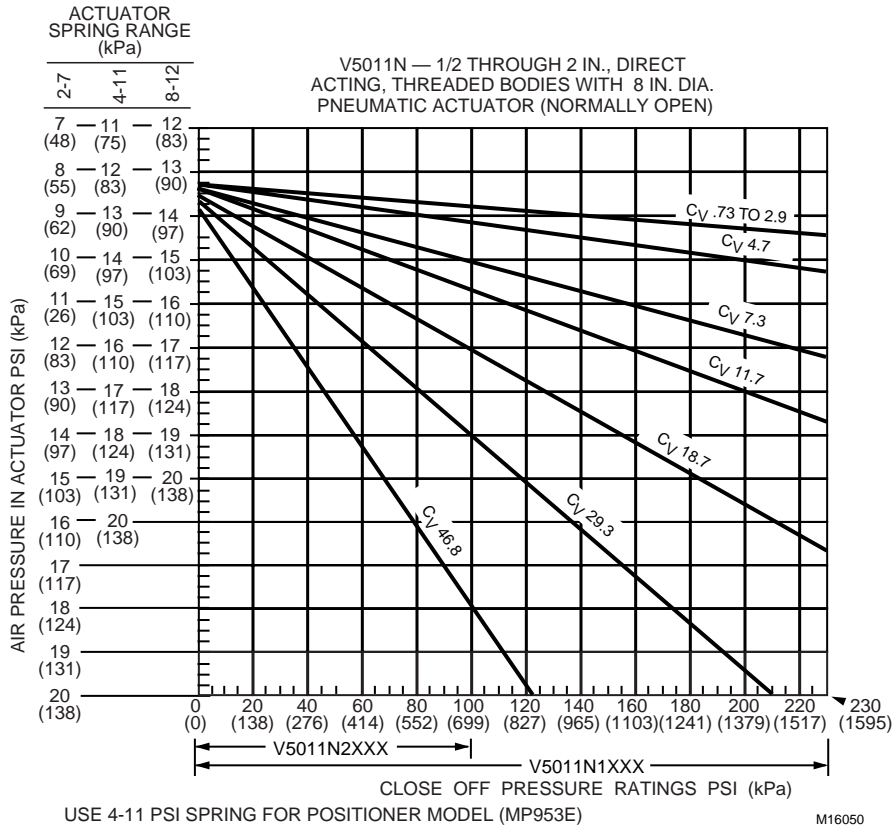
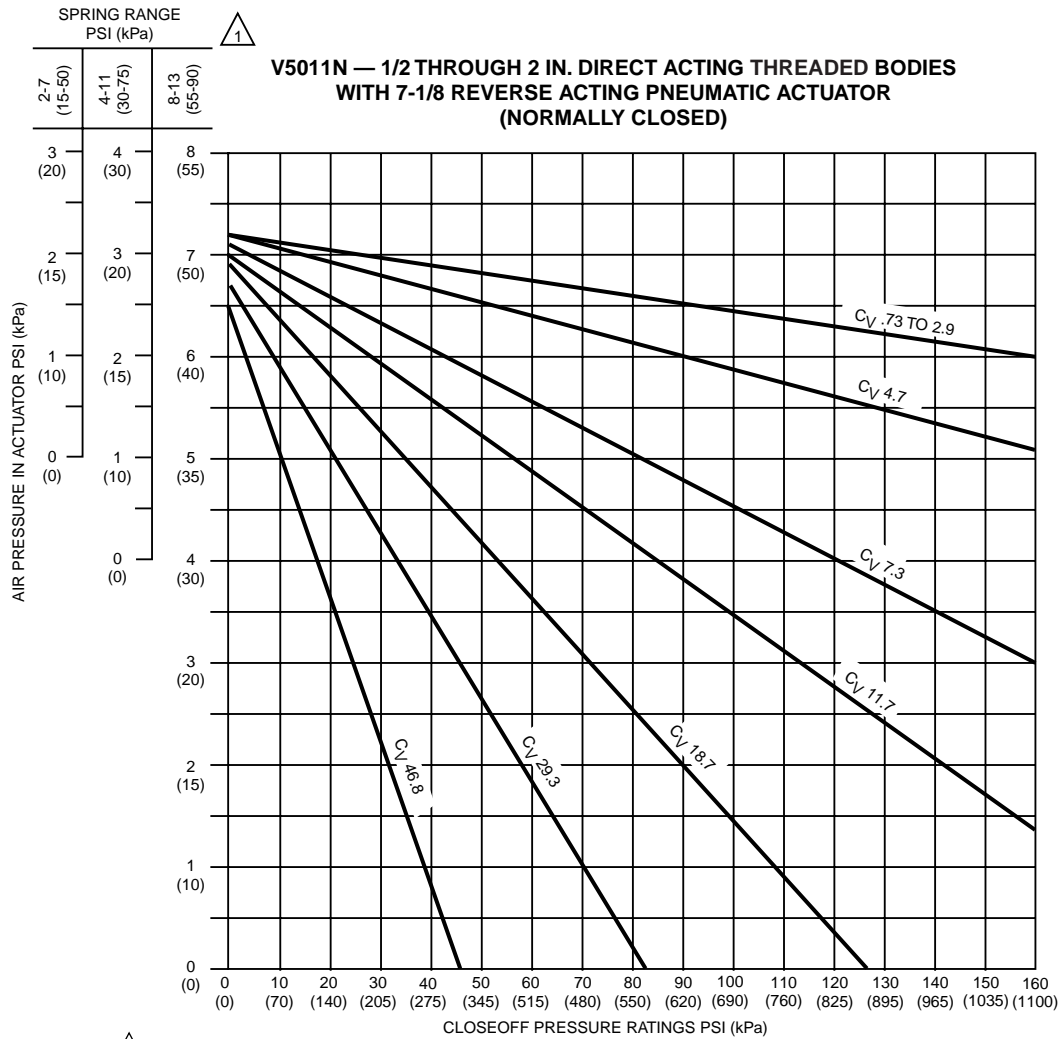
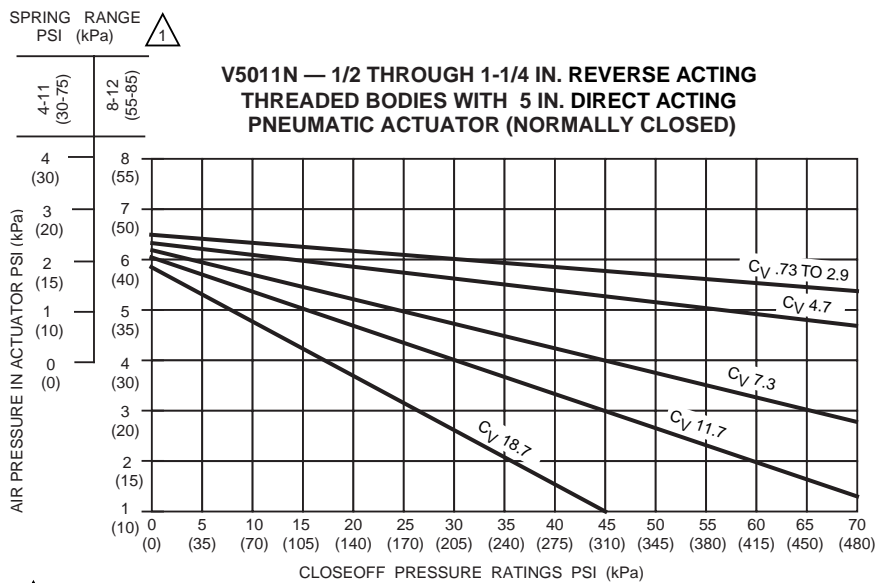

Fig. 2. Close-off pressures at various control air pressures for V5011N Valves and MP953 Pneumatic Actuators (continued).



1 USE 8-13 PSI (55-90 KPA) RANGE FOR DETERMINING CLOSEOFF OF VALVES USED WITH MP953F ACTUATORS.

M16051



1 USE 4-11 PSI (30-75 KPA) RANGE FOR DETERMINING CLOSEOFF OF VALVES USED WITH MP953E ACTUATORS.

M16052

Fig. 2. Close-off pressures at various control air pressures for V5011N Valves and MP953 Pneumatic Actuators (continued).

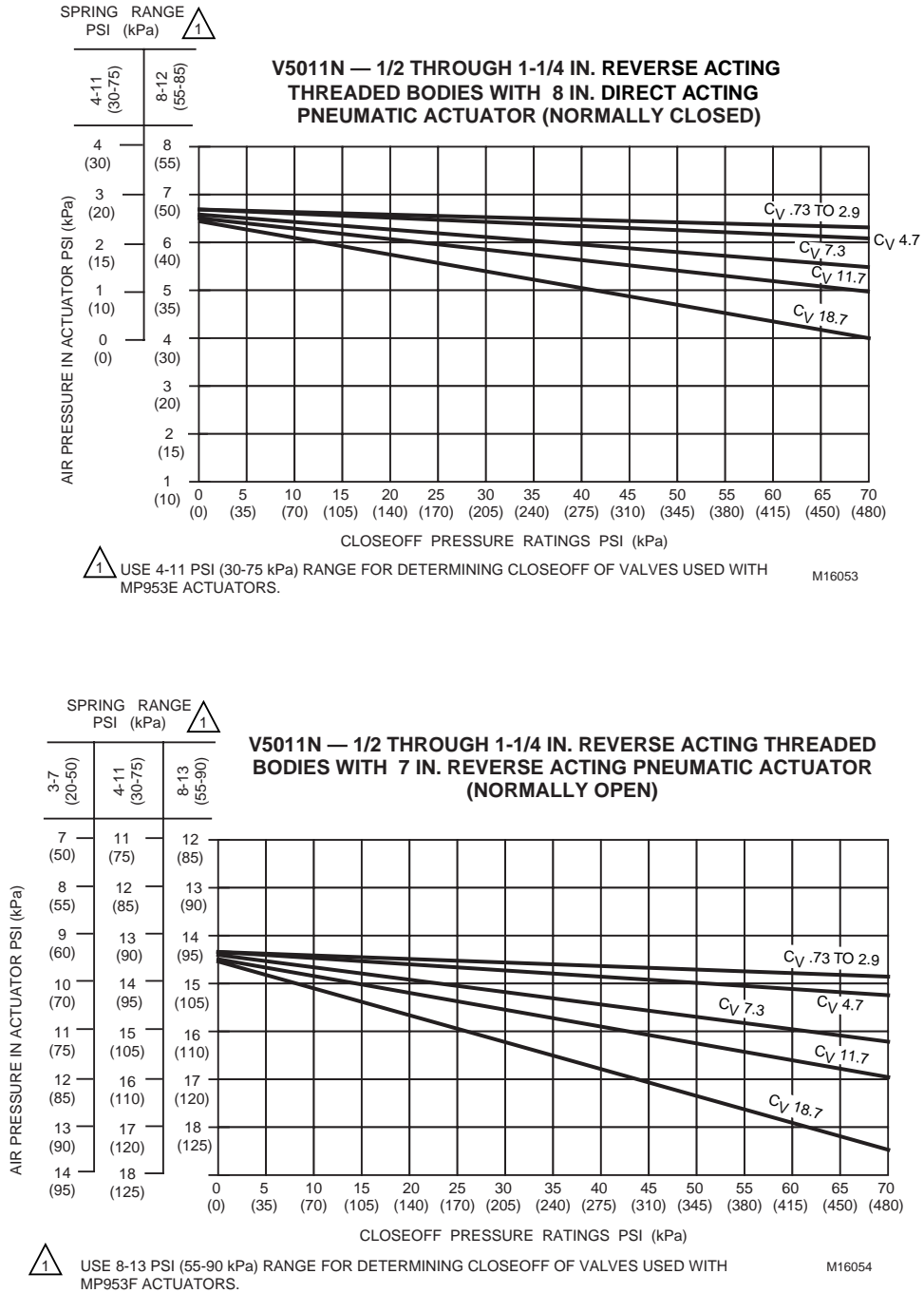

Fig. 2. Close-off pressures at various control air pressures for V5011N Valves and MP953 Pneumatic Actuators (continued).

Table 2. Close-off ratings (psid) for V5011N1xxx and V5011N3xxx Valves with electric/electronic actuators.

Valve Size (NPT)	Mod IV Motor with Q5001 Linkages			ML6421A,B ML7421A,B	ML6425A,B ML7425A,B	ML7984, ML6874
	320 lb	160 lb	80 lb	405 lb	135 lb	160 lb
1/2 in. (C _v = .73 to 2.9)		230 ^a	230 ^a		230 ^a	230 ^a
1/2 in. (C _v = 4.7)		230 ^a	230 ^a		230 ^a	230 ^a
3/4		230 ^a	131		230 ^a	230 ^a
1	230 ^a	196	91	230 ^a	163	196
1-1/4	230 ^a	126	57	230 ^a	104	126
1-1/2	173	81	36	221	67	81
2	98	46	19	126	37	46

^aPressure is limited by fluid temperature. See valve temperature/pressure ratings.

Table 3. Close off ratings (psid) for V5011N2xxx Valves with electric/electronic actuators.

Valve Size (NPT)	Mod IV Motor with Q5001 Linkages			ML6421A,B ML7421A,B	ML6425A,B ML7425A,B	ML7984, ML6874
	320 lb	160 lb	80lb	405 lb	135 lb	160 lb
1/2 in. (C _v = .73 to 2.9)		100 ^a	100 ^a		100 ^a	100 ^a
1/2 in. (C _v = 4.7)		100 ^a	100 ^a		100 ^a	100 ^a
3/4		100 ^a	100 ^a		100 ^a	100 ^a
1	100 ^a	100 ^a	91	100 ^a	100 ^a	100 ^a
1-1/4	100 ^a	100 ^a	57	100 ^a	100 ^a	100 ^a
1-1/2	100 ^a	81	36	100 ^a	67	81
2	98	46	19	100 ^a	37	46

^aPressure limited by fluid temperature; see valve temperature/pressure ratings.

Maximum Pressure Differential for Quiet Water Service:
20 psi differential.

Rangeability:
50:1 per VDI/VDE 2173.

Dimensions:
See Fig. 3.

Motor and Linkage Selection:

Electric	Pneumatic
ML6421/ML6425	MP953 (except 13")
ML7421/ML7425	
ML7984/ML6874	
Mod IV w/Q5001	

Replacement Parts:
See Fig. 4.

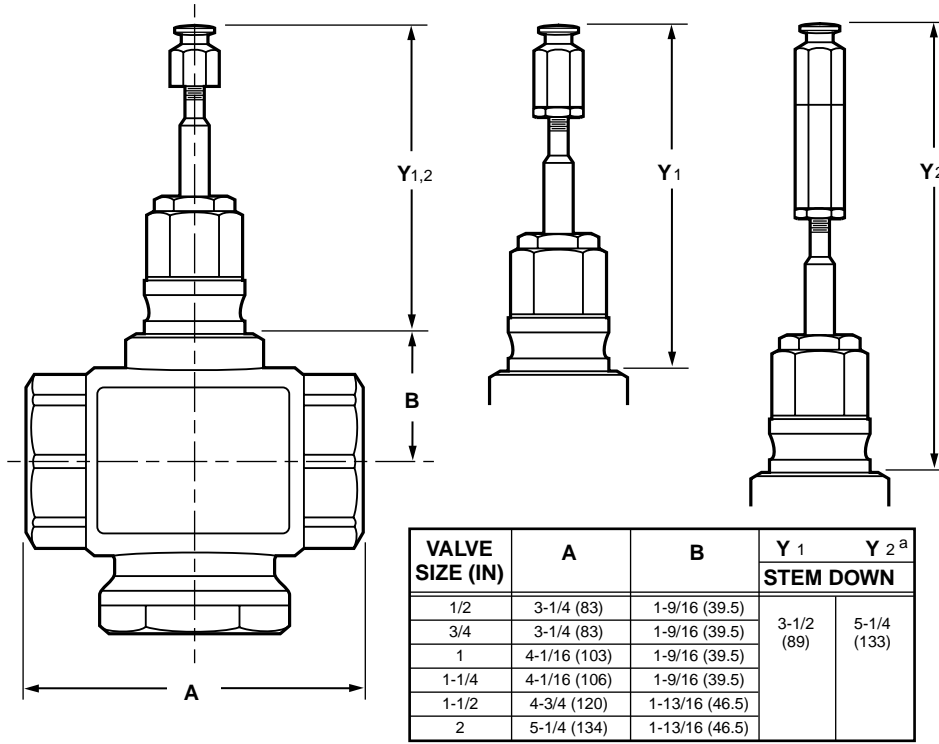

^aY₂ WITH STEM EXTENSION FOR MP953A,C (8 IN. ONLY) M16047

Fig. 3. V5011N body dimensions in in. (mm).

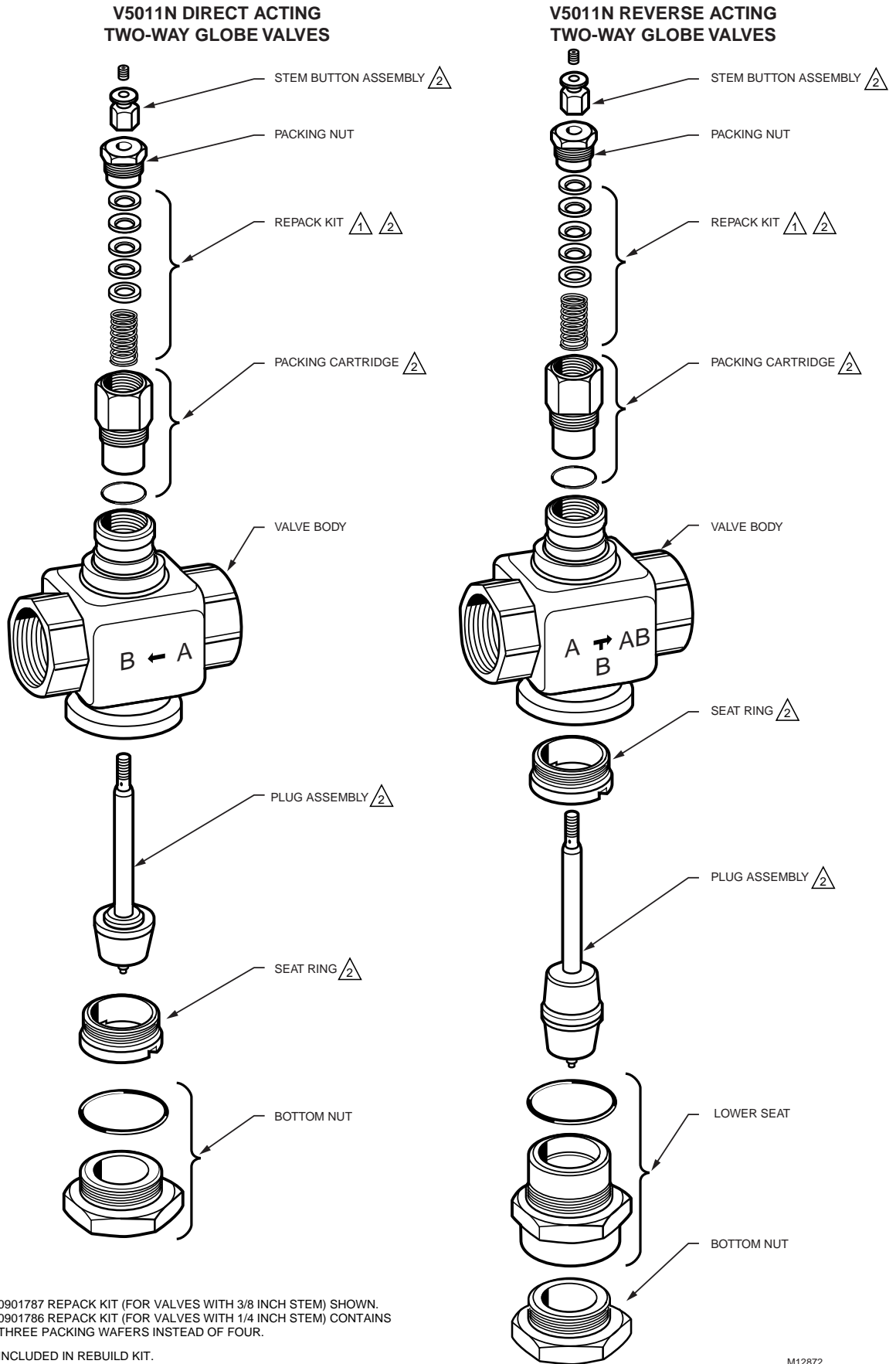

1 0901787 REPACK KIT (FOR VALVES WITH 3/8 INCH STEM) SHOWN. 0901786 REPACK KIT (FOR VALVES WITH 1/4 INCH STEM) CONTAINS THREE PACKING WAFERS INSTEAD OF FOUR.

2 INCLUDED IN REBUILD KIT.

Fig. 4. V5011N replacement parts.

M12872

Valve OS No.	NPT Size (in.)	Flow Capacity (C _v)	Stem Diameter (in.)	Repack Kit (Part No.)	Rebuild Kit (Part No.)	Stem Button (Part No.)
V5011N1008	1/2	0.73	1/4	0901786	0901746A	0901116
V5011N1016		1.16			0901747A	
V5011N1024		1.85			0901748A	
V5011N1032		2.9			0901749A	
V5011N1040		4.7			0901750A	
V5011N1057		3/4			7.3	
V5011N1065	1	11.7	0901752A			
V5011N1073	1-1/4	18.7	0901753A			
V5011N1081	1-1/2	29.3	3/8	0901787	0901754A	
V5011N1099	2	46.8			0901755A	
V5011N2006	1/2	0.73	1/4	0901786	0903422A	
V5011N2014		1.16			0903423A	
V5011N2022		1.85			0903424A	
V5011N2030		2.9			0903425A	
V5011N2048		4.7			0903426A	
V5011N2055		3/4			7.3	0903427A
V5011N2063	1	11.7	0903428A			
V5011N2071	1-1/4	18.7	0903429A			
V5011N2089	1-1/2	29.3	3/8	0901787	0903430A	
V5011N2097	2	46.8			0903431A	
V5011N3004	1/2	2.9	1/4	0901786	0901759A	
V5011N3012		4.7			0901760A	
V5011N3020	3/4	7.3	0901761A			
V5011N3038	1	11.7	0901762A			
V5011N3046	1-1/4	18.7	0901763A			

INSTALLATION

When Installing This Product...

1. Read these instructions carefully. Failure to follow them could damage the product or cause a hazardous condition.
2. Check the ratings given in the instructions and on the product to make sure the product is suitable for your application.
3. Installer must be a trained, experienced service technician.
4. After installation is complete, check out product operation as provided in these instructions.

IMPORTANT

1. Do not lift the valve by holding the stem.
2. Do not mount the valve with the stem pointed lower than horizontal.
3. Mount the valve with the flow arrow pointed in the direction of flow through the valve.
4. Mount the valve between aligned pipes. Mounting the valve on pipes that are not aligned causes leakage at the valve-to-pipe connection.
5. Ensure complete engagement on pipe to valve body threads.
6. Hold the valve body with a clamp or pipe wrench on the hexagonal fitting nearest the pipe to prevent damage to the valve body while mounting on the pipe. Refer to Fig. 5.
7. Be sure to allow enough room for installation and service. Clearance for valve installation is dependent on actuator size and the valve pipe size.

Location

Select a location where the valve, linkage (if used), and actuator to be used are within the appropriate ambient pressure and temperature ratings.

Leave sufficient clearance above the valve to accommodate actuator installation and allow room for servicing the valve body. (Completely install the valve body in the pipe line before installing the actuator and linkage.)

When selecting a location for the valve, consider actuator mounting restrictions. Modutrol IV™ Motor chankshafts must be mounted horizontally.

Mounting

The preferred valve mounting position is with the stem vertical. For steam applications, mount with the stem at a 45 degree angle. Do not mount the valve with the stem more than 90 degrees from the vertical (pointing lower than horizontal). Scale and foreign material can collect, scoring the stem and causing packing leakage. Protect the stem from damage due to bending or scratching.

Threading on threaded bodies conform to American Standard Taper Pipe Threads (NPT).

Align the pipes squarely with the valve at each end connection. If the pipes are forced into the valve, the body can become twisted and improper seating can result. Apply pipe dope sparingly. Be careful to prevent pipe debris, such as chips and scale, from entering the piping because this material can lodge in the seat and prevent proper closing.

Refer to the table in Fig. 5 for valve pipe sizes and thread lengths. Fig. 5 also shows two effective methods of holding the valve and pipe when attaching it. The valve will not function properly if it is twisted or squeezed during installation.

Refer to installation information furnished with the linkage and motor when installing these controls.

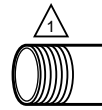

PIPE SIZE (IN.)	EFFECTIVE LENGTH OF THREADS IN IN. (MM)	
1/2	1/2	(12.7)
3/4	9/16	(14.3)
1	11/16	(17.5)
1-1/4	11/16	(17.5)
1-1/2	11/16	(17.5)
2	3/4	(19.1)

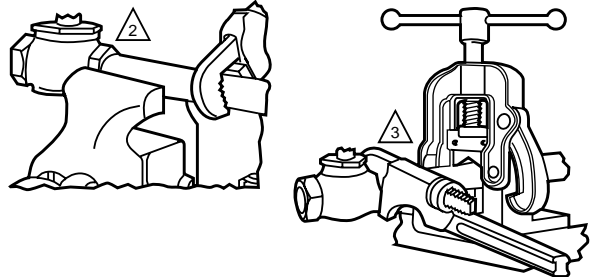

- 1 USE PROPERLY REAMED AND CLEANED PIPE AND MODERATE AMOUNT OF DOPE (LEAVE TWO THREADS BARE).
- 2 USE VISE GRIPS WITH THE HEX END NEXT TO THE PIPE (DO NOT TWIST OR SQUEEZE VALVE BODY).
- 3 USE VISE TO HOLD PIPE SECURELY TO PREVENT TURNING. USE PARALLEL-JAW WRENCH TO GRIP VALVE HEX FLATS NEXT TO PIPE.

M11763A

Fig. 5. Installing valves with threaded connections.

CHECKOUT

Before installing linkage (if used) and actuator, make sure that valve stem operates freely. Impaired stem operation can indicate that the body was twisted or the stem was bent. Either of these conditions may require valve replacement.

Check the valve body and connections for leaks. After installing linkage and actuator, check the operation according to the installation information furnished with these controls. Operate the system through one complete cycle to be sure the valve controls properly.

Check the valve at regular intervals for leakage around the packing. The packing is spring-loaded and should seldom require attention. If leakage is discovered and inspection shows that the packing gland is screwed down tightly, the repack the valve.

Home and Building Control

Honeywell Inc.
Honeywell Plaza
P.O. Box 524
Minneapolis MN 55408-0524

Honeywell Latin American Region

480 Sawgrass Corporate Parkway
Suite 200
Sunrise FL 33325

Home and Building Control

Honeywell Limited-Honeywell Limitée
155 Gordon Baker Road
North York, Ontario
M2H 3N7

Honeywell Europe S.A.

3 Avenue du Bourget
1140 Brussels
Belgium

Honeywell Asia Pacific Inc.

Room 3213-3225
Sun Hung Kai Centre
No. 30 Harbour Road
Wanchai
Hong Kong

Honeywell

