

7800 SERIES

S7830 Expanded Annunciator

The Honeywell 7800 SERIES is a microprocessor based integrated burner control for automatically or semi-automatically fired gas, oil, coal, or combination fuel single burner applications. The 7800 SERIES provides a level of safety, functional capability and features beyond the capacity of conventional controls. Functions provided by the 7800 SERIES include: automatic burner sequencing, flame supervision, system status indication, system or self-diagnostics and troubleshooting. The 7800 SERIES consists of a Relay Module, Flame Amplifier, Universal Mounting Subbase, Plug-In Purge Timer and optional Keyboard Display Module, Remote Reset, and Communications Interface for integrating personal computer networking.

The S7830 Expanded Annunciator is an enhancement module for use with any 7800 SERIES Relay Module. The S7830 is a microprocessor based device designed to monitor the status of a series string of limit, control, and interlock contacts for a commercial or industrial burner. The S7830 acts as a system monitor and enhances fault and status messages of the 7800 SERIES burner control.

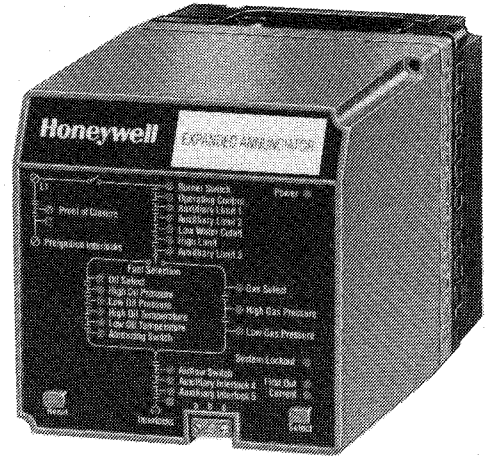

- 26 status LEDs.
- Front panel LED array—arranged in a pattern to clearly indicate the flow of line-voltage through the string of limits, controls, and interlocks.
- Selectable current and first-out LED array display status.
- Power and proper operation indicating LED.
- Common Universal Mounting Subbase (Q7800 A or B).
- 2 1 monitored contact points.
- Access for external electrical voltage checks.
- Communication interface capability.
- S7800 Keyboard Display Module data:
 - Device type.
 - Software revision and version.
 - Expanded Annunciator current status.
 - First-out fault code.
 - Status (on/off) of all line voltage monitored contact points.
- LED operational test.
- 36 additional 7800 SERIES fault and hold messages.

CONTENTS

Specifications..	2
Ordering Information	2
Principal Technical Features	4
Installation	4
Wiring	5
Operation	8
Checkout	12



Specifications

ELECTRICAL RATINGS (See Table 1):

Voltage and Frequency: 120 Vac +10/-15%, 50 or 60 Hz +/-10 %.

Power Dissipation: 4.6W maximum.

TABLE 1—TERMINAL RATINGS

Terminal Number	Description	Rating
1	Earth Ground ¹	
2	Input Line Voltage (Neutral)	120 Vac +10/-15%
3	Input Line Voltage (Hot)	
4	Main Valve Proof Of Closure	120 Vac +10/-15%, 2 mA
5	Burner Switch	
6	Operating Control	
7	Auxiliary Limit # 1	
8	Auxiliary Limit # 2	
9	Low Water Cutoff	
10	High Limit	
11	Auxiliary Limit # 3	
12	Oil Select Switch	
13	High Oil Pressure	
14	Low Oil Pressure	
15	High Oil Temperature	
16	Low Oil Temperature	
17	Gas Select Switch	
18	High Gas Pressure	
19	Low Gas Pressure or Atomizing Switch	
20	Air Flow Switch	
21	Auxiliary Interlock # 4	
22	Auxiliary Interlock # 5	

¹ The S7830 must have an earth ground providing a connection between the subbase and the control panel or the equipment. The earth ground must be capable of conducting the current to blow a 20A fuse (or breaker) in event of an internal short circuit. The S7830 needs a low impedance ground connection to the equipment frame that, in turn, needs a low impedance connection to earth ground. For a ground path to be low impedance at RF frequencies, the connection must be made with minimum length conductors that have maximum surface areas. Wide straps or brackets rather than leadwires are preferred. Be careful to verify that the mechanically tightened joints along the ground path, such as pipe or conduit threads or surfaces held together with fasteners, are free of nonconductive coatings and are protected against mating surface corrosion.

Ordering Information

When purchasing replacement and modernization products from your 7800 SERIES distributor, refer to the TRADELINE® Catalog for complete ordering number.

If you have additional questions, need further information, or would like to comment on our products or services, please write or phone:

1. Your local Home and Building Control Sales Office (check white pages of your phone directory).
2. Home and Building Control Customer Satisfaction

Honeywell Inc., 1885 Douglas Drive North
Minneapolis, MN 554224386 (612) 542-7500

In Canada-Honeywell Limited/Honeywell Limitee, 740 Ellesmere Road, Scarborough, Ontario M1P2VP. International Sales and Service Offices in all principal cities of the world. Manufacturing in Australia, Canada, Finland, France, Germany, Japan, Mexico, Netherlands, Spain, Taiwan United Kingdom, U.S.A.

ENVIRONMENTAL RATINGS:

- Ambient Temperature:
- Operating: -40° F to 140° F
- Storage: - 40° F to 150° F
- Humidity: 85% continuous, noncondensing
- Vibration: 0.5 G environment

DIMENSIONS:

Refer to Figs. 1 and 2.

WEIGHT:

1 pound 6 ounces, unpacked

APPROVAL BODIES:

- Underwriters Laboratories Inc. listed: File No. MH17367, Guide No MJAT.
- Canadian Standards Association certified: LR95329.
- Factory Mutual Approved.
- IRI Acceptable.

Federal Communications Commission: Part 15, Class B Emissions.

MOUNTING:

- Q7800A two sided subbase for control panel mounting.
- Q7800B four sided subbase for external from control panel mounting.

REQUIRED COMPONENTS:

- Q7800A or Q7800B Universal Wiring Subbase.
- 7800 SERIES Primary Safety Control Relay Module.
- S7800 Keyboard Display Module or S7810 DATA CONTROLBUS MODULE.

ACCESSORIES:

- Optional:
- Communications Interface Base Unit Q7700A.
- Communication ControlBus Module QS7800A.
- Combustion System Manager Personal Computer Software ZM7850.

Fig. 1-Mounting dimensions of S7830 Expanded Annunciator and Q7800A Subbase in inches [mm].

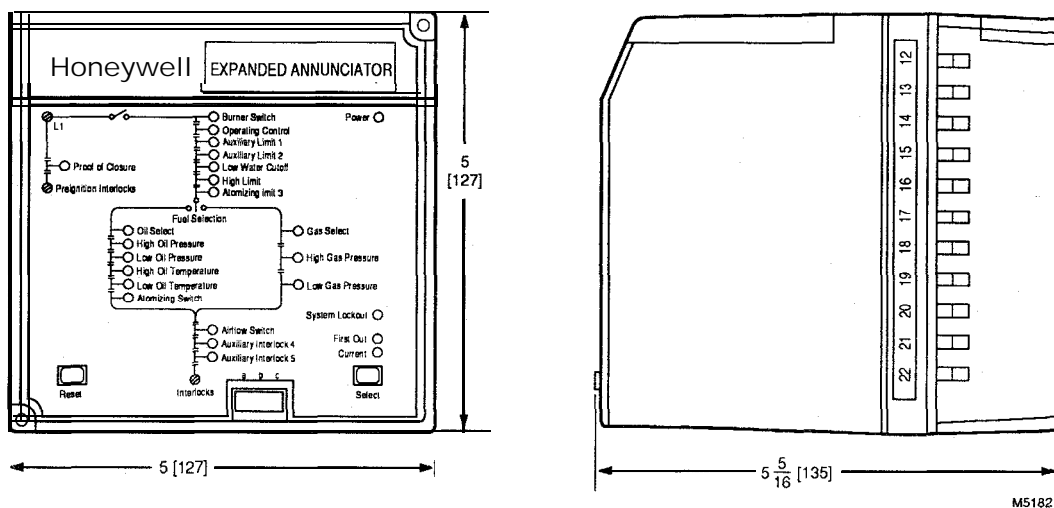
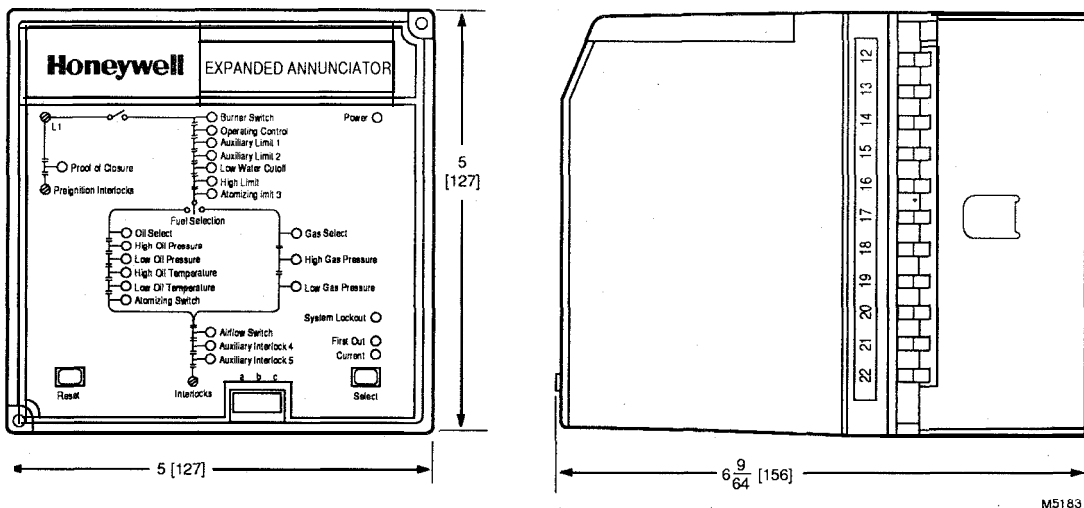

Fig. 2—Mounting dimensions of S7830 Expanded Annunciator and Q7800B Subbase in inches [mm].



Principal Technical Features

The S7830 Expanded Annunciator is an enhancement module for use with any 7800 SERIES Relay Module. The S7830 is a microprocessor based device designed to monitor the status of a series string of limit, control, and interlock contacts for a commercial or industrial burner. The S7830 acts as a system monitor and enhances fault and status messages for the 7800 SERIES burner control.

CONTROLBUS COMMUNICATIONS

The S7830 provides interfaces with the 7800 SERIES Relay Module through a three wire RS-485 interface. Using this communication bus, the S7830 provides additional **first-out annunciation, burner hold, and current status information** for the control, limit, and interlock string of the burner equipment.

LED ARRAY

The S7830 provides visual indication of the status of the burner equipment control, limit, and interlock string. The

string of contact and switch points are individually identified with a colored LED. When power is present at the contact point, the LED is illuminated. When the contact point is de-energized, the LED is dark. If the contact or switch is identified as the **first-out annunciation point**, the LED flashes.

OPTO-ISOLATOR COUPLING

The S7830 utilizes opto-isolators to couple the line voltage input to the micro-processor. An opto-isolator allows a micro-processor to determine the status of line voltage at control, limit, or interlock switch points. Using this capability, the micro-processor is able to determine the current as well as first-out status of twenty-three digital points, each representing specific burner control, limit, or interlock switches.

Installation



WARNING

FIRE OR EXPLOSION HAZARD CAN CAUSE PROPERTY DAMAGE, SEVERE INJURY, OR DEATH.

Verification of safety requirements must be performed *each time* a control is installed on a burner to prevent possible hazardous burner operation.

WHEN INSTALLING THIS PRODUCT...

1. Read these instructions carefully. Failure to follow them could damage the product or cause a hazardous condition.
2. Check the ratings given in the instructions and on the product to make sure the product is suitable for your application.
3. Installer must be a trained, experienced, flame safeguard technician.
4. After installation is complete check out the product operation as provided in these instructions.



CAUTION

1. Disconnect the power supply before beginning installation to prevent electrical shock and equipment damage. More than one power supply disconnect may be involved.
2. Wiring connections for the S7830 are unique; therefore, refer to Fig. 3 for proper subbase wiring.
3. Wiring must comply with all applicable codes, ordinances and regulations.
4. Wiring must comply with NEC Class 1 (Line Voltage) wiring.
5. Loads connected to the S7830 must not exceed those listed in the Specifications, see Table 1.
6. The S7830 should not interfere with the proper safety operation of the controls, limits, and interlocks it is monitoring. After installation, check each control, limit, and interlock to ensure it is operating properly. **DO NOT PLACE JUMPER WIRES ACROSS THE INSTALLATION CONTROLS, LIMITS, AND INTERLOCKS.**

IMPORTANT:

1. This equipment generates, uses and can radiate radio frequency energy and, if not installed and used in accordance with these instructions, may cause interference to radio communications. It has been tested and found to comply with the limits of a Class B computing device of part 15 of FCC rules, which are designed to provide reasonable protection against such interference when operated in a commercial environment. Operation of this equipment in a residential area may cause interference; in which case, the user at their own expense may be required to take whatever measures are required to correct this interference.
2. This digital apparatus does not exceed the Class B limits for radio noise, set out in the Radio Interference Regulations of the Canadian Department of Communications.
3. If a control, limit, or interlock is not used with the installation, a jumper must be installed on the S7830 wiring subbase. **DO NOT PLACE JUMPER WIRES ACROSS THE INSTALLATION CONTROLS, LIMITS, AND INTERLOCKS.** For example, if Auxiliary Limit # 1 (Aux Limit #1) is not used, place a jumper wire between terminals 6 and 7 on the S7830 wiring subbase.
4. For straight gas burner applications, the oil limit and interlock inputs **DO NOT** need to be jumpered.
5. For straight oil burner applications, the gas limit and interlock inputs **DO NOT** need to be jumpered.
6. For combination gas-oil burner applications, a double poledouble throw (dpdt) fuel select switch is required, see Fig.3.
7. For communications ControlBus connections in excess of 100 feet, a 120 ohm (1/4 watt minimum) termination resistor must be placed across terminals 1 (a) and 2 (b) of the electrical connectors at the closest and farthest end of the daisy chain.

8. The 7800 SERIES Relay Module control point can be tied into the S7830:
 - For dual fuel burners, from terminals 6 to 11, inclusive.
 - For single fuel burners, from terminals 6 to 19, inclusive.

HUMIDITY

Install the S7830 where the relative humidity never reaches the saturation point. The S7830 is designed to operate in a maximum 85% RH continuous, noncondensing, moisture environment. Condensing moisture may cause erratic operation.

VIBRATION

Do not install the S7830 where it could be subjected to excessive vibration, 0.5G continuous maximum.

WEATHER

The S7830 is not designed to be weather tight. If installed outdoors, the S7830 must be protected by a weather-tight, NEMA 4, enclosure.

MOUNTING WIRING SUBBASE

NOTE: For installation dimensions, see Figs. 1 or 2.

1. Mount the subbase in any position except horizontally with the bifurcated contacts pointing down. A vertical mounting position is recommended. Any other positions decrease the maximum ambient temperature rating.
2. Select a location on a wall, burner surface, or within an electrical control panel. Be sure to allow adequate clearance for electrical voltage probe tests, electrical field connections, and wiring of the RS-485 ControlBus to the 7800 SERIES Relay Module. The S7830 must be within 1000 feet of the 7800 SERIES Relay Module for proper communication of first-out annunciation and current burner status information.
3. Use the back of the subbase as a template to mark the four screw locations, and drill pilot holes.
4. Insert four no. 6 screws for mounting and tighten securely.

Wiring

1. Refer to Fig. 3 for proper subbase wiring.
2. Disconnect the power supply from the main disconnect before beginning installation to prevent electrical shock and equipment damage. More than one disconnect may be involved.
3. Ail wiring must comply with all appropriate electrical codes, ordinances, and regulations. Wiring, where required, must comply with NBC Class 1 (Line Voltage).
4. Recommended wire size and type:
 - Line voltage:
Use no. 14, 16, or 18 gauge (TTW60C or THW75C or THHN90C), 600 volt insulation for all Line Voltage terminals.
 - RS-485 ControlBus:
Use an unshielded three-wire twisted cable. Some installations may require shielded cable, Belden 8771 or equivalent. The connection to the 57800

Keyboard Display Module, S7810 DATA CONTROLBUS MODULE, or QS7800 Communications Interface ControlBus Module must be wired in a daisy chain configuration, 1 (a) - 1 (a), 2 (b) - 2 (b), 3 (c) - 3 (c). The **order** of interconnection of all the devices listed above is not important. For connections in excess of 100 feet, a 120 ohm (114 watt minimum) termination resistor must be placed across terminals 1 (a) and 2 (b) of the electrical connectors at the closest and farthest end of the daisy chain.

5. Recommended grounding practices:
 - a. The earth ground provides for a connection between the wiring subbase and the control panel or the equipment. The earth ground wire must be capable of conducting the current to blow the 20A fuse (or breaker) in event of an internal short circuit.

The S7830 needs a **low impedance ground connection** to the equipment frame which, in turn, needs a low impedance connection to earth ground. For a **ground path to be low impedance at RF frequencies**, the connection must be made with minimum length conductors that have a maximum surface area. Wide straps or brackets are preferred rather than leadwires. Be careful to ensure that mechanically tightened joints along the ground path, such as pipe or conduit threads or surfaces held together with fasteners, are free of nonconductive coatings and are protected against corrosion on mating surfaces.

- b. The ControlBus shielded cable, if used, should be connected to the signal ground terminal 3 (c) provided as part of the S7830 ControlBus connector.

The shield should be connected at both ends to earth ground.

- 6. Recommended Wire Routing:
 - a. Communications ControlBus:
 - 1. Do not run high voltage ignition transformer wires in the same conduit or close proximity with the ControlBus wiring.
 - 2. Do not route the ControlBus wires in conduit with line voltage circuits.
- 7. Maximum wire lengths:
 - a. Communications ControlBus:
 - 1. The maximum ControlBus cable length depends on the number of system modules connected, the noise conditions and the cable used. The maximum length of all interconnecting wire is 1000 feet.

Fig. 3—S7830 wiring hookup.

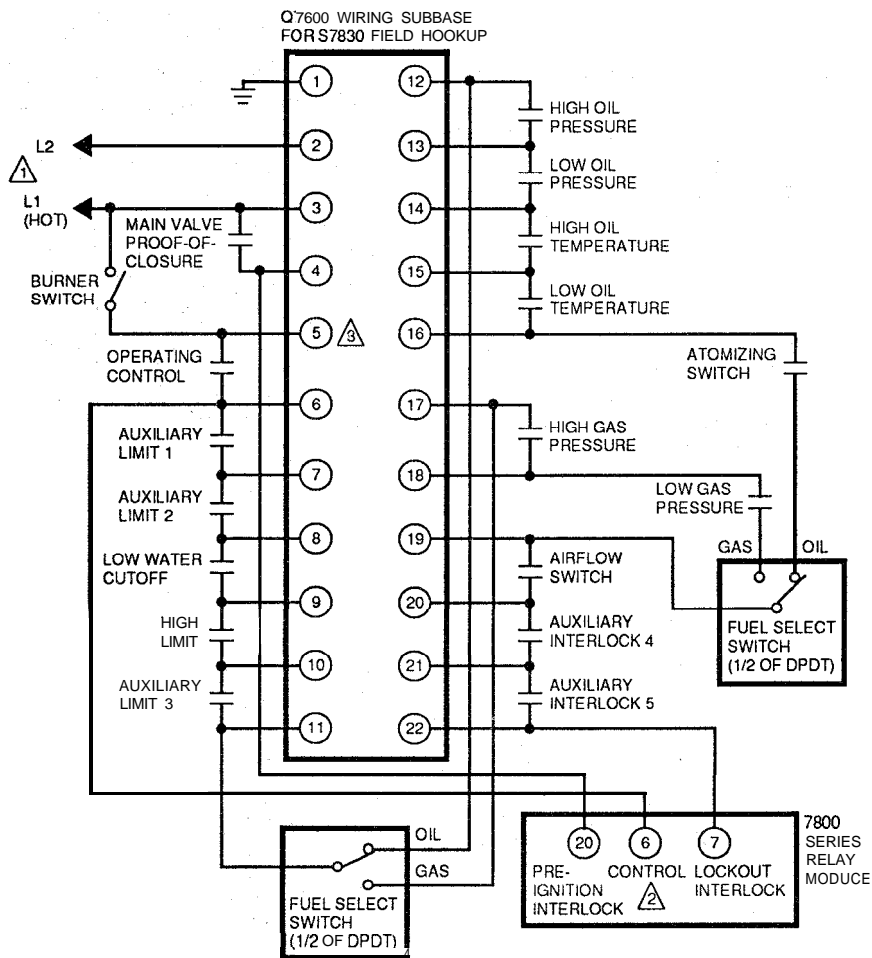

- ⚠ 120V, 50/60 Hz POWER SUPPLY. PROVIDE DISCONNECT MEANS AND OVERLOAD PROTECTION AS REQUIRED.
- ⚠ IN DUAL FUEL SYSTEMS, 7600 SERIES-T6 CAN BE TIED TO ANY POINT FROM 6 TO 11, INCLUSIVE. IN SINGLE FUEL SYSTEMS, 7600 SERIES-T6 CAN BE TIED TO ANY POINT FROM 6 TO 19, INCLUSIVE. (ANYTHING BEFORE THIS POINT IS CONSIDERED A LIMIT AND ANYTHING AFTER IT IS CONSIDERED AN INTERLOCK.)
- ⚠ PLACE JUMPERS ON S7830 WIRING SUBBASE ONLY FOR UNUSED CONTROL, LIMIT, OR INTERLOCKS. M5173

Fig. 4—Wiring the RS-485 ControlBus

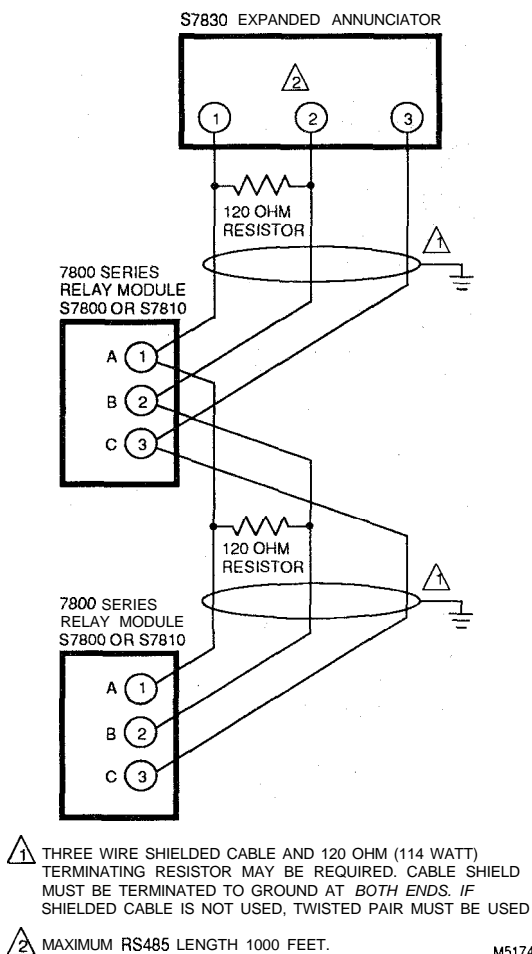

Fig. 5—Electrical panel installation.

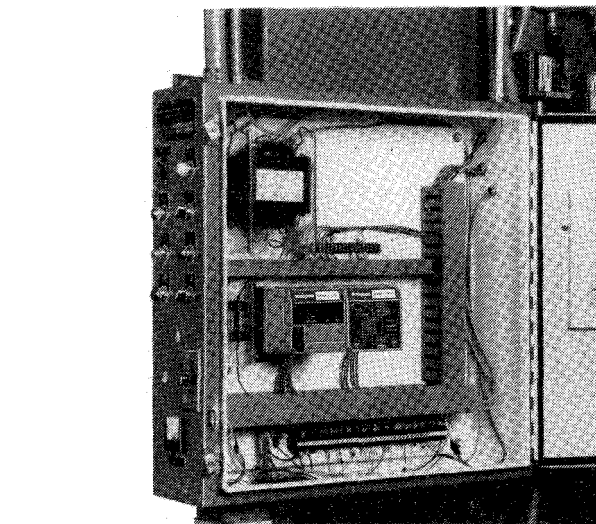
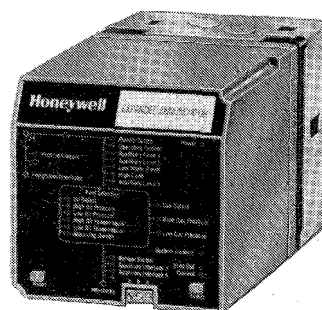

Fig. 6—Wall or burner installation.



2. S7830 leadwires - The maximum length of the control, limit, and interlock leadwires is 500feet to the terminal inputs.
8. Make sure loads do not exceed the terminal ratings. Refer to the ratings in the Specifications, Table 1.
9. Check the power supply circuit. The voltage and frequency tolerance must match those of the S7830. Do not connect the S7830 to a power supply circuit that can have wide line voltage variations. A separate power supply circuit may be required for the S7830. Add the required disconnect means and overload protection.
10. Check all wiring circuits, see Fig. 3, before installing the S7830 on the wiring subbase.
11. Install all electrical connectors.
12. Restore power to the panel.

MOUNTING THE S7830

NOTE: For installation dimensions, see Figs. 1 or 2.

1. Mount the S7830 vertically (see Figs. 5, 6, and 7) or horizontally with the knife blade terminals pointing downward. When mounted on the Q7800A wiring subbase, the S7830 must be in an electrical enclosure.
2. Select the location in the electrical enclosure. Be sure to allow clearances for servicing, electrical signal voltage probes, and electrical connections. Allow an optional three inches minimum on both sides of the S7830 for electrical signal voltage probes.
3. Make sure no subbase wiring is projecting beyond the terminal blocks. Tuck in wiring against the back of the subbase so it does not interfere with the knife blade terminals or bifurcated contacts.
4. Mount the S7830 by aligning the four L shaped corner guides and knife blade terminals with the bifurcated contacts on the wiring subbase and securely tightening the two mounting screws.

Fig. 747830.

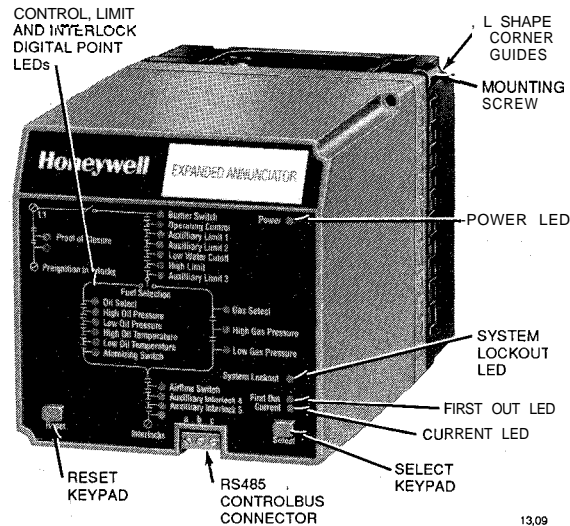

Operation

The S7830 is designed to operate in conjunction with 7800 SERIES Relay Modules to enhance information for causes of burner lockouts and sequence status by monitoring up to 21 digital contact points. Current burner status and lockout information is displayed at the S7830 through an array of 26 LEDs and also on the face of the S7800 Keyboard Display Module. The information from the S7830 is communicated through a three-wire twisted ControlBus communications link to the S7800 and/or the QS7800 Communications ControlBus Module to be integrated with ZM7850 Combustion System Manager PC Software.

FIRST-OUT ANNUNCIATION

The S7830 does not cause burner lockouts, because only the 7800 SERIES Relay Module can cause a burner lockout (safety shutdown) for abnormal conditions. From the time a lockout occurs, the expanded first-out annunciation is communicated as follows:

1. The 7800 SERIES Relay Module causes a lockout due to, for example, the opening of the Lockout Interlock circuit.
2. The 7800 SERIES Relay Module communicates the lockout status to any modules connected to the RS485 ControlBus communication network including the time when the fault occurred.
3. The S7830 recognizes the lockout status of the 7800 SERIES Relay Module and the time when the fault occurred.
4. The S7830 begins to review the status of all switched inputs on a grouping of several line cycles time duration. When identifying a normal status of all switched inputs, the S7830 will advance one line cycle grouping to identify the first switched input that opened after the normal status. This

switch point, for example, air flow switch, is identified as the first-out annunciation point.

5. This first-out information is communicated by the S7830 to:

- a. The 7800 SERIES Relay Module to enhance the lockout display message, for example, from Lockout Interlock fault to Airflow Switch fault.
- b. The array of 26 status LEDs on the face of the S7830 that are latched to the lockout mode to visually indicate which switch is the first-out point. For the example being used:
 - All LEDs electrically upstream from the airflow switch will be illuminated constantly.
 - The airflow switch LED will flash on and off to indicate that this switch was the first-out cause of the lockout condition.
 - Any LEDs electrically downstream from the first-out point will remain dark because the circuit upstream of that point has been broken.
 - The first-out LED will be latched to indicate the mode of the 26 LED array.

6. When the lockout is cleared, by resetting the 7800 SERIES Relay Module, the S7830 mode is automatically changed from first-out to current.

CURRENT STATUS

The S7830 provides current status information, through the RS485 ControlBus, defining which switch point is causing a hold condition. The 7800 SERIES Relay Module places the burner in Standby when the control input, terminal 6, opens. The exact switch causing the burner to enter Standby may be one of several controls, limits, or interlocks. The

S7830, through the RS-485 ControlBus, communicates the current status of the 21 monitored digital contact points twice each second. For example, if the Standby hold is being caused by the Burner Switch being open, the Standby hold message will be enhanced to identify the Burner Switch, providing information that identifies the reason for the hold.

S7830 User Interface

LED STATES

The array of 26 LEDs can have the following states:

- Digital Points

The digital contact switch points can have one of three states:

- LED ON indicates power is present at the S7830 terminal monitoring that switch.
- LED OFF indicates power is absent at the S7830 terminal monitoring that switch.
- LED FLASHING indicates the switch that is the cause of the lockout, first-out point.

Digital Points LEDs:

- Main Valve Proof Of Closure
- Burner Switch
- Operating Control
- Auxiliary Limit # 1
- Auxiliary Limit # 2
- Low Water Cutoff
- High Limit
- Auxiliary Limit # 3
- Oil Select Switch
- High Oil Pressure
- Low Oil Pressure
- High Oil Temperature
- Low Oil Temperature
- Gas Select Switch
- High Gas Pressure
- Low Gas Pressure or Atomizing Switch
- Air Flow Switch
- Auxiliary Interlock # 4
- Auxiliary Interlock # 5
- Other Preignition Interlock
- Other Lockout Interlock

- Power LED

The Power LED can have one of three states:

- LED ON indicates an abnormal condition that shows power is present at the S7830, but the device is inoperative (reset the S7830).
- LED OFF indicates:
 - Power is absent at the S7830.
 - Power is present at the S7830, but the Power LED is defective.
 - Power is present at the S7830, the Power LED is not burned out, but the device is inoperative (reset the S7830).
- LED FLASHING (off briefly every four seconds) indicates power is present at the S7830 and the device is operating properly.

- System Lockout LED

The System Lockout LED can have one of two states:

- LED ON indicates the 7800 SERIES Relay Module is in a lockout status.
- LED OFF indicates the 7800 SERIES Relay Mod-

ule is in a normal operating status, power is off, or the LED is defective.

- First-out LED

The First-out LED can have one of three states:

- LED ON indicates the LED array is latched in a mode showing the status at the time of the lockout.
- LED OFF indicates the LED array is in a Current status mode, power is off, or the LED is defective.
- LED FLASHING indicates the Select keypad is being depressed constantly (4 seconds or longer) and a Lockout is not present.

- Current LED

The Current LED can have one of two states:

- LED ON indicates the LED array is in a Current status.
- LED OFF indicates the LED array is latched in a first-out mode, power is off, or the LED is defective.

SELECT KEYPAD FUNCTIONS

The Select keypad provides two functions:

1. When depressed momentarily, the S7830 mode will toggle between lockout (first-out) and Current status. Therefore, the operator can actively switch back and forth between these two modes to define the status of the 21 digital switched inputs.

2. When depressed constantly (four seconds), all 25 LEDs (exclusive of the Power LED) in the array will be forced on. This is a means to check to make certain that an LED can illuminate or is operating properly.

RESET KEYPAD FUNCTION

The Reset keypad is used to cause an electrical reset of the S7830. If the operation of the S7830 is in question, an attempt can be made to reset the internal microprocessor. It is not necessary to depress the Reset keypad after a system lockout. Once the 7800 SERIES Relay Module is reset, the S7830 LED array automatically will be reset to the Current status mode.

DISPLAY MESSAGES

The S7830 is used to enhance the lockout and hold information generated by the 7800 SERIES Relay Module, and allows point-by-point interrogation of the digital switch points by using the S7800 Keyboard Display Module and/or ZM7850 Combustion System Manger PC software. This information is contained within an Expanded Annunciator informational index, see Table 2.

S7800/ZM7850 EXPANDED ANNUNCIATOR INFORMATIONAL INDEX

Using the S7800 and/or ZM7850 PC software, referring to Table 2, the individual ON/OFF status of 22 digital points can be monitored. The display message values for the Expanded Annunciator Informational Index are also explained in Table 2.

HOLD MESSAGES

Using the S7800 and/or ZM7850 PC software, the S7830 provides 16 HOLD messages. The HOLD messages are summarized in Table 3.

LOCKOUT MESSAGES

Using the S7800 and/or ZM7850 PC software, the S7830 provides 20 enhanced LOCKOUT messages. The LOCKOUT messages are summarized in Table 4.

TABLE 2—EXPANDED ANNUNCIATOR INFORMATIONAL INDEX

Selectable Message	Display Value	Description
EA not connected		The Expanded Annunciator (EA) is not connected.
CS:	Reference Table 5	Current status of Expanded Annunciator (EA) digital switch points.
Valve Close	ON or OFF	The main valve proof of closure switch is open (OFF) or closed (ON)
Burner Sw.		The burner switch switch is open (OFF) or closed (ON).
OperControl		The operating control (pressure or temperature) switch is open (OFF) or closed (ON)
Aux Limit 1		An auxiliary limit switch is open (OFF) or closed (ON).
Aux Limit 2		An auxiliary limit switch is open (OFF) or closed (ON).
LWCO		The low water cutoff switch is open (OFF) or closed (ON).
High Limit		The appliance high limit (pressure or temperature) switch is open (OFF) or closed (ON)
Aux Limit 3		An auxiliary limit switch is open (OFF) or closed (ON).
Oil Select		The fuel oil select switch is open (OFF) or closed (ON).
HiOilPres		The high oil pressure limit switch is open (OFF) or closed (ON).
LowOilPres		The low oil pressure limit switch is open (OFF) or closed (ON).
HiOilTemp		The high oil temperature limit switch is open (OFF) or closed (ON).
LowOilTemp		The low oil temperature limit switch is open (OFF) or closed (ON).
Atomize S w		The oil atomizing proving switch is open (OFF) or closed (ON)
Gas Select		The has select switch is open (OFF) or closed (ON).
HiGasPres		The high gas pressure limit switch is open (OFF) or closed (ON).
LowGasPres		The low gas pressure limit switch is open (OFF) or closed (ON)
Airflow Sw		The airflow interlock switch is open (OFF) or closed (ON)
Aux ILK 4		An auxiliary interlock switch is open (OFF) or closed (ON).
Aux ILK 5		An auxiliary interlock switch is open (OFF) or closed (ON)
EA Fault Code	nnn	The fault code number, identifying the specific Expanded Annunciator fault.
SW Rev.	nnnn	Identifies the software revision of the S7830.

TABLE 3-EXPANDED ANNUNCIATOR HOLD CODES.

Message	Description
BURNER OFF: T6 (Burner Switch)	Burner switch is open (OFF) and keeping the burner in an Off condition.
STANDBY HOLD: T6 (Aux Limit # 1)	Auxiliary limit # 1 is open (OFF) and keeping the burner in Standby.
STANDBY HOLD: T6 (Aux Limit # 2)	Auxiliary limit # 2 is open (OFF) and keeping the burner in Standby.
STANDBY HOLD: T6 (LWCO)	Low water cutoff is open (OFF) and keeping the burner in Standby.
STANDBY HOLD: T6 (High Limit)	The appliance high limit is open (OFF) and keeping the burner in Standby.
STANDBY HOLD: T6 (Aux Limit # 3)	Auxiliary limit # 3 is open (OFF) and keeping the burner in Standby.
STANDBY HOLD: T6 (FuelSelectOff)	Both fuel select inputs are open (OFF) and keeping the burner in Standby.
STANDBY HOLD: T6 (BothFuelSelect)	Both fuel select inputs are closed (ON) and keeping the burner in Standby.

TABLE 3—EXPANDED ANNUNCIATOR HOLD CODES (Continued)

Message	Description
STANDBY HOLD: T6 (High Oil Press)	High oil pressure limit is open (OFF) and keeping the burner in Standby.
STANDBY HOLD: T6 (Low Oil Press)	Low oil pressure limit is open (OFF) and keeping the burner in Standby.
STANDBY HOLD: T6 (High Oil Temp)	High oil temperature limit is open (OFF) and keeping the burner in Standby.
STANDBY HOLD: T6 (Low Oil Temp)	Low oil temperature limit is open (OFF) and keeping the burner in Standby.
STANDBY HOLD: T6 (Atomizing Sw.)	Oil atomizing switch is open (OFF) and keeping the burner in Standby.
STANDBY HOLD: T6 (High Gas Press)	High gas pressure limit is open (OFF) and keeping the burner in Standby.
STANDBY HOLD: T6 (Low Gas Press)	Low gas pressure limit is open (OFF) and keeping the burner in Standby.
STANDBY HOLD: T6 (Circuit Fault)	Control input is not energized.

TABLE 4—EXPANDED ANNUNCIATOR LOCKOUT CODES.

Message	Description
LOCKOUT nna *Aux.Limit#1*	Auxiliary Limit # 1 was open.
LOCKOUT nmb *Aux.Limit#2*	Auxiliary Limit # 2 was open.
LOCKOUT nnc *LWCO*	Low water cutoff was open.
LOCKOUT nnd *High Limit*	Appliance high limit was exceeded.
LOCKOUT nne *Aux.Limit#3*	Auxiliary Limit # 3 was open.
LOCKOUT nnf *FuelSelectOff*	No fuel was selected.
LOCKOUT nng *BothFuelSelect*	Both fuels were selected.
LOCKOUT nnh *High Oil Press*	Oil pressure was above the high limit setting.
LOCKOUT nni *Low Oil Press*	Oil pressure was below the low limit setting.
LOCKOUT nnj *High Oil Temp*	Oil temperature was above the high limit setting.
LOCKOUT nnk *Low Oil Temp*	Oil temperature was below the low limit setting.
LOCKOUT nnm *Atomizing Sw.*	Atomizing switch failed to close.
LOCKOUT nnn *High Gas Press*	Gas pressure was above the high limit setting.
LOCKOUT nno *Low Gas Press*	Gas pressure was below the low limit setting.
LOCKOUT nnp *Airflow Switch*	The airflow switch was open (OFF) when it should have been closed (ON). Or the airflow switch was closed (ON) when it should have open (OFF).
LOCKOUT nnq *Aux.ILK#4*	Auxiliary Interlock # 4 was open.
LOCKOUT nnr *Aux.ILK#5*	Auxiliary Interlock # 5 was open.

TABLE "EXPANDED ANNUNCIATOR LOCKOUT CODES (continued)

Message	Description
LOCKOUT nns *Other ILKs*	An interlock, electrically downstream of Auxiliary Interlock # 5, was open
LOCKOUT nny *Valve Closure*	Main valve proof of closure switch was open.
LOCKOUT nnz *Other PII*	An interlock, electrically downstream of the main valve proof of closure (Valve Closure), was open

TABLE 5-EXPANDED ANNUNCIATOR CURRENT STATUS MESSAGES.

Message	Description
Burner Sw.	Burner Switch
Oper. Control	Operating Control
Aux. Limit # 1	Auxiliary Limit # 1
Aux. Limit # 2	Auxiliary Limit # 2
LWCO	Low Water Cutoff
High Limit	High temperature or pressure Limit
Aux. Limit # 3	Auxiliary Limit # 3
FuelSelectOff	Fuel Select switch is off.
BothFuelSelect	Both fuel select inputs are on.
High Oil Pres.	High Oil Pressure
Low Oil Pres.	Low Oil Pressure
Low Oil Temp.	Low Oil Temperature
Atomizing Sw.	Atomizing Switch
High Gas Pres.	High Gas Pressure
Low Gas Pres.	Low Gas Pressure
Airflow Sw.	Airflow Switch
Aux. ILK # 4	Auxiliary Interlock # 4
Aux. ILK # 5	Auxiliary Interlock # 5

Checkout

Several basic steps can be taken to check proper operation of the S7830.

1. Depress and hold the Select keypad for five seconds. All 25 LEDs (exclusive of the Power LED) should illuminate.
2. Through the S7800 Keyboard and Display Module or ZM7850 PC software, access the Expanded Annunciator Informational Index. If the S7830 is operating properly, it should be possible to access the status of all switched points.
3. Open equipment control, limits, and interlock inputs. The S7830 LED array, S7800 Keyboard Display Module, and ZM7850 PC software should indicate the cause of the burner lockout and switched point status.

IMPORTANT: Restore ALL controls, limits, and interlock inputs to proper operation altered in step 3. DO NOT PLACE JUMPER WIRES ACROSS THE INSTALLATION CONTROLS, LIMITS, AND INTERLOCKS.

If improper operation is identified, check all S7830 wiring against Fig. 3 and correct any errors. If problems persist, reset the S7830. If problems continue to persist, replace the S7830 Expanded Annunciator.

Honeywell

Home and Building Control

Honeywell Inc.
1985 Douglas Drive North
Golden Valley, Minnesota 55422

Home and Building Control

Honeywell Limited-Honeywell Limit&e
740 Ellesmere Road
Scarborough, Ontario
M1P 2V9

Helping You Control Your World

