

DD-05

Thermostat

USE'S GUIDE

CONTENTS

Application/Features	1
Specifications	2
Function Keys And Displays Description	3-4
Function and Feature	5-7
Key Function Description	8
Auto Mode Settings/Manual Mode Settings	9-14
Energy-saving Mode Setting	15
7-day Program Copy	16
QUERY Function	17
Temporary temperature setting/Constant Temperature Control	18
Installing Fig. Illustration	19-20
Circuit Diagram	23

Application

DD-05 thermostat is used to set temperature for the separate household central air-conditioning system, under-floor electric heating system or other heat-supply systems.

Features

LED Backlit Professional-Grade Large Screen Display

Simultaneously Displaying Room Temperature and Current Clock Time

An Unlimited Time Memory During Power Interruption

Temperature Unit In Degrees Fahrenheit or Celsius

Vacation Mode and Holding Temperature Mode For Comfort and Energy Savings.

Setting Temperature in One 7-day preprogrammed schedule (Monday through Sunday) and During Maximum 6 Occupied Time Periods Each Day

Temperature Correction Function

Specifications

Supply Voltage: 100~240VAC, 50/60Hz; two AAA alkaline batteries
(power to hold operation during power interruption)

Displayed Temperature Range: 5°C~45°C/41°F~113°F

Temperature Accuracy: 0.5°C/1°F

Operating Temperature: 0°C~+50°C(32°F~122°F)

Maximum Load : 16A/250V

Dimensions: 108mmX88mmX21mm

Function Keys and Displays

Description

Keys Description (Fig.1)

- ① Increase: raises temperature setting
- ② Mode Changeover: selects auto, manu or energy savings, and time
- ③ Decrease: lowers temperature setting
- ④ Query/copy
- ⑤ Set/confirm

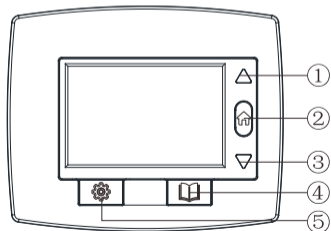
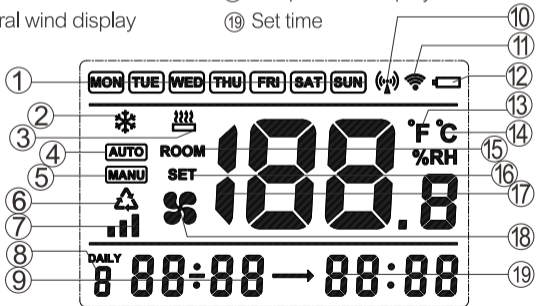

Fig.1

Displaying Description(Fig.2)

- | | | | |
|------------------------------------|---------------------------------------|---------------|-------------|
| ① Display day of the week | ② Cool | ③ Heat | ④ Auto mode |
| ⑤ Manual mode | ⑥ Energy savings mode | | |
| ⑦ Fan speed(low, mid, high) | ⑧ Serial number of time period | | |
| ⑨ Set current day/time | ⑩ Wireless signal | ⑪ Wifi signal | |
| ⑫ Battery level display | ⑬ Fahrenheit temperature display (°F) | | |
| ⑭ Celsius Temperature display (°C) | ⑮ Room mode display | | |
| ⑯ Set | ⑰ Temperature display | | |
| ⑱ Natural wind display | ⑲ Set time | | |



Function and Feature

1. Mode

- ① DAY Mode: It's a one-day preprogrammed schedule mode. your thermostat is programmable for each day, and the occupied time period you want during one day can be set. The maximum number of occupied time periods is 6. The start time and stop time of every occupied time period can be modified, and the stop time of the last period is the start time of the next period by default.
- ② Week Mode: It's a 7-day preprogrammed schedule mode. Your thermostat is 7-day programmable from Monday through Sunday. The stop time of the last day is the start time of the next week period by default.
- ③ Output Mode: in output mode, the defrosting temperature can be controlled, and you can set temperature.

2. Time and Temperature Displaying

- ① System Time Setting: select the desired year, month, day, hour, minute, a day of the week.

- ② **Temperature Display:** Temperature can be displayed in degrees Fahrenheit (°F) or Celsius(0°C). when the power supply is switched on, the displayed temperature value is zero, and the first sampled temperature value can be displayed after the power supply is switched on for 10 seconds. In idle, The room temperature is displayed and refresh once every 20 seconds. (in idle, no operation on your thermostat before normal displaying, otherwise, abnormal displaying occurs.)

3. Temperature Setting





The range of temperature set: 5°C~45°C(41°F~113°F); the displayed value to one decimal place; the first displayed temperature is 21°C by default. Pressing “▲” or “▼” key increase or decrease in 0.5°C increment once.

4. Battery Level Display

- ① Low-voltage warning can be shown on the LED display if the battery level is lower than 2.4V.
- ② In case the battery level is lower than 2V, the thermostat will stop running and only the low-voltage warning is shown on the LED display.

5. Anti-disturbance: When strong interference signal is removed, all the functions will automatically recover.
6. Self Test: when sensors experience failures, the device will be automatically detected by itself, and then the LED display will show all the contents of 7-segment display .
7. Power-down data protection: in the event of an unexpected power interruption, the last settings will be saved in the device. After re-power on, all the stored data will automatically recovered.
8. Language Displayed: English
9. Query: you can check the settings for all the time periods from Monday through Sunday.
10. Setting copy: if the settings for one day is same as for another day. The present settings can be copied to another day without repeating setting.

Key Function Description:

1. Increase data key “▲” : pressing increase “▼” key continuously, temperature time value fast raises to the desired set point.
2. Changeover MODE key: Press the key “MODE” and hold for several seconds to set the current date and clock.
 - (1) Pressing and holding the key "  ", a day of week will be shown. Press the key “▲” or “▼” to select the desired day of the week, and then press the key "  " to set. With the same method, you can select the year/month/date/hour/minute you want, at last press the key "  " to set and save the data settings.
 - (2) Press mode changeover "  " key until the desired mode, **AUTO**, or **MANU**, or , displays.
3. Decrease data key “▼” : pressing decrease key “▼” continuously, temperature time value fast drops to the desired set point.



Auto Mode Settings

	Time Period	Start time ~ Stop time	Operating
Daylight	1 st period	6:00-18:00	Press the Mode Changeover key "⚙️" to enter to set data for the 1 st time period. Press the key "▲" or "▼" until the desired temperature displays and then press the Set key "⚙️" to enter to set data for the 2 nd time period with the same step as the 1 st time period, and at last press the Set key "⚙️" to save the set data.
Night	2 nd period	18:00-6:00	



Manual Mode Settings

In MANU mode, your thermostat is 7-day programmable. Your thermostat automatically runs and controls the device up to the desired temperatures during every time period based on the preprogrammed schedule in a circle of a week. 7-day programming means to set time periods and temperatures during each time period for each day from Monday through Sunday.

1. In "**MANU**" mode
2. Press the key "⚙️" to set (Fig.1)
3. The 7-segment LCD display flashing (Fig.2)
4. Press the key "▲" or "▼" to select the desired day of the week (Fig.2)
5. Press the key "⚙️" to save the setting (Fig.1)

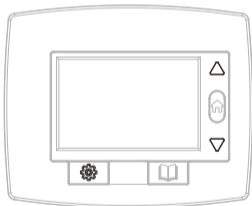

Fig.1



Fig.2

- The DAILY display flashing (Fig.2)
- Press the key "▲" or "▼" to select the desired DAILY 1-6 (Fig.2)
- Press the key "⚙️" to save the setting (Fig.1)



Fig.1



Fig.2

9. The desired hours of the time period 1 display flashing (Fig.2)
10. Press the key “▲” or “▼” to select the desired hours (Fig.2)
11. Press the key "⚙️" to save the setting (Fig.1)

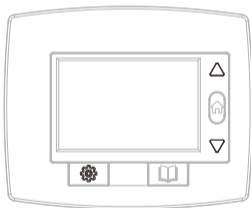

Fig.1



Fig.2

12. The desired minute of the time period 1 display flashing (Fig.2)
13. Press the key “▲” or “▼” to select the desired minute (Fig.2)
14. Press the key "⚙️" to save the setting (Fig.1)

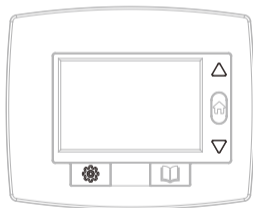

Fig.1



Fig.2

15. The desired temperature display flashing (Fig.2)
16. Press the key "▲" or "▼" to select the desired temperature (Fig.2)
17. Press the key "⚙️" to save the setting (Fig.1)

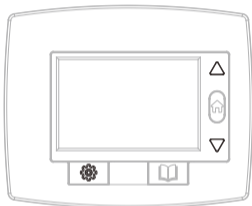

Fig.1

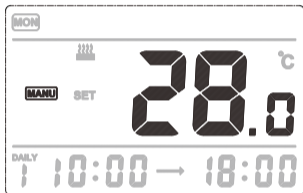

Fig.2





At the last time to press the key "⚙️", the daily schedule (one day of a 7-day schedule) is now programmed and all the setting datas can be stored as well as the thermostat return to normal operation



Repeat the above steps for the occupied time period 1 through 6 for any day of the week .

Energy-saving Mode setting

In energy saving mode, only one desired temperature can be set without time period setting.

1. In "  "mode
2. Press the key "  " to set (Fig.1)
3. The temperature display flashing (Fig.2)
4. Press the key "  " or "  " to select the desired temperature of the week (Fig.2)
5. Press the key "  " to save the setting (Fig.1)

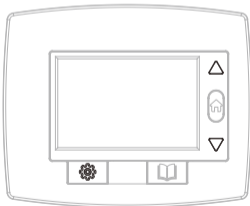

Fig.1

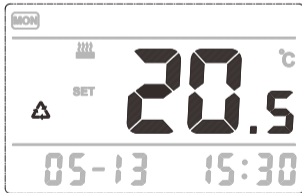









Fig.2

4. Pressing and hold the key "Query/copy", can achieve Temperature Correction Factor.

(1) 7-day Program Copy

This copying function is to copy the programmed time periods and temperature points for any designated day to any another day.

1. In " **MANU** " mode
2. Press the key "  " to set (Fig.1)
3. Press the key "  " or "  " to select the desired day of the week (Fig.2)
4. Press the key "  " to copy (Fig.1)
5. Press the key "  " or "  " to select the desired day of the week (Fig.3)
6. Press the key "  " to determine (Fig.1)

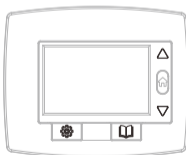

Fig.1



Fig.2

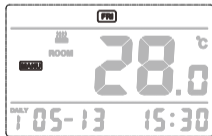



Fig.3

(2) QUERY Function

Press the "  "key in MANU mode to enter the **MANU** mode, you can check the temperature set point for the any programmed day.





1. In "**MANU**" mode
2. Press the key "  " to query (Fig.1)
3. Press the key "▲" or "▼" to select the desired day of the week (Fig.2)
4. Press the key "  ", the temperature set point of the occupied time period 1 will be displayed (Fig.3)
5. Press the key "  " again to quit "MANU" mode
6. Press "  " every time, display in turn the temperature setting values of the occupied time period from 2 to 6.



Fig.1



Fig.2



Fig.3

5. Set “SET” key

Pressing “” key for 3 second can switch between temperature unit in degrees Fahrenheit and Celsius

Temporary temperature setting

You can override the current schedule period to temporarily change the temperature setting for an occupied time period by pressing “▲” or “▼” key in normal mode. If no any operation during 5 seconds after the temporary setting, the temporary temperature setting will be in effect.

Constant Temperature Control

If the detected temperature is lower 0.5°C than the set temperature, the signal to start heating will be sent once every 5 minutes. If the detected temperature is higher 0.5°C than the set temperature, the signal to stop heating will be sent once every 5 minutes.

Installation

(1) Replacing Batteries

See Fig.1. Remove the upper cover; Insert two AAA alkaline batteries as shown in Fig.2; Install the upper cover as shown in Fig.3.

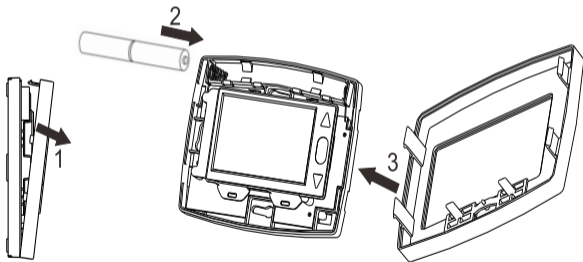

(2) Installing on wall plate as shown in the following Fig.s

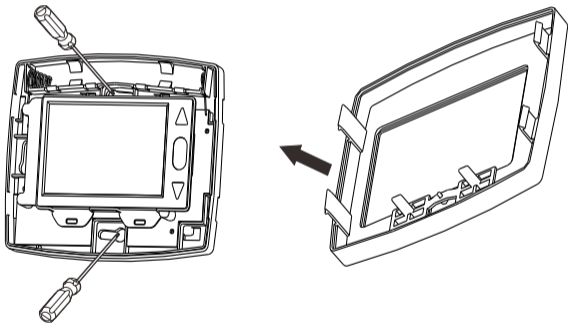

Wiring Diagram

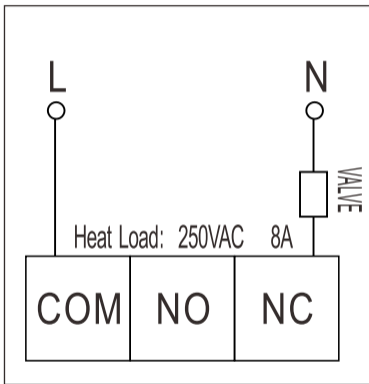

www.heatcool.cn

CE

