

Q5020A-D Globe Valve Linkages FOR DIRECT COUPLED ACTUATORS

PRODUCT DATA



FEATURES

- Used with 2-way and 3-way globe valves in modulating or two-position service.
- Used with 25, 50, and 142 lb-in. spring return and 35, 70, 150, and 300 lb-in. non-spring return DCA.
- Quick and simple installation with no disassembly required.
- Heavy-duty steel rack and pinion construction and aluminum die-cast housing.
- Maintenance-free construction.
- Precision roller-bearing rack construction prevents premature valve packing wear and leakage.
- Flexible actuator mounting orientation.
- Adjustable manual override lever and valve position indicator.
- Can be mounted on specific non-Honeywell valves using a 32004629 Bonnet Adapter Kit.

APPLICATION

The Q5020 Globe Valve Linkages connect a Honeywell direct coupled damper actuator to a steam or water globe valve. The Q5020 Linkages are compatible with 2- and 3-way globe valves.

Contents

Application	1
Features	1
Specifications	2
Ordering Information	2
Installation	6
Checkout	8



SPECIFICATIONS

Models: See Table 1.

Dimensions: See Fig. 1.

Temperature Range:

Ambient Range: -40°F to 140°F (-40°C to 60°C).

Medium Range: 32°F to 337°F (0°C to 169°C).

Actuator Required: See Table 2 for valve-actuator combinations.

Close-off Ratings:

Threaded Valves: See Table 3.

Flange Valves: See Table 4.

Materials of Construction:

Housing: Die-cast aluminum.

Rack and Pinion Gears: Steel and powdered metal.

Manual Override Lever: Steel.

Accessories:

32004629-001 Bonnet Adapter Kit for 1/2 to 3 in. Siemens Globe Valves.

32004629-002 Bonnet Adapter Kit for 1/2 and 3/4 in. Johnson Globe Valves.

32004629-003 Bonnet Adapter Kit for 1 to 2 in. Johnson Globe Valves.

32004629-004 Bonnet Adapter Kit for 1/2 to 2 in. Siebe Globe Valves.

Table 1. Q5020 Models.

Model	Stroke ^a (in.)	Shaft (in.)	Compatible Valve Sizes (in.)	Compatible DCA Torque (lb-in.)
Q5020A	3/4	1/2	1/2 to 3	25 to 150 (Spring and Non-Spring Return)
Q5020B	3/4	1	1/2 to 3	300 (Non-Spring Return)
Q5020C	1-1/2	1	2-1/2 to 6	142 (Spring Return) or 300 (Non-Spring Return)
Q5020D	1/2	1/2	See Table 2	25 to 150 (Spring and Non-Spring Return)

^a Applies to the Q5020 and compatible valves.

ORDERING INFORMATION

When purchasing replacement and modernization products from your TRADELINE® wholesaler or distributor, refer to the TRADELINE® Catalog or price sheets for complete ordering number.

If you have additional questions, need further information, or would like to comment on our products or services, please write or phone:

1. Your local Home and Building Control Sales Office (check white pages of your phone directory).
2. Home and Building Control Customer Logistics
Honeywell Inc., 1885 Douglas Drive North
Minneapolis, Minnesota 55422-4386 (612) 951-1000

In Canada—Honeywell Limited/Honeywell Limitée, 155 Gordon Baker Road, North York, Ontario M2H 3N7.

International Sales and Service Offices in all principal cities of the world. Manufacturing in Australia, Canada, Finland, France, Germany, Japan, Mexico, Netherlands, Spain, Taiwan, United Kingdom, U.S.A.

Table 2. Acceptable Q5020 Linkage, Honeywell Valve, Actuator Combinations.

Valve						Actuator Torque (lb-in.)				
Body	Required Bonnet Adapter Kit	Model	Connection	Size (in.)	Stroke (in.)	Non Spring Return			Spring Return	
						35/70	150	300	25/53	142
Honeywell Valves										
Globe	None	V5011, V5013	NPT	1/2 to 3	3/4	Q5020A	Q5020A	Q5020B	Q5020A	Q5020A
		V3350,51,60,61, V3450,51,60,61	Flanged	2 1/2 to 3 ^a						
Double-seated	None	V5047	NPT	1/2 to 3	9/16 to 3/4					
Cage	None	V5051	Flanged	2-1/2 to 6	1-1/2	—	—	Q5020C	—	Q5020C
Siemens (Landis, Powers) Valves										
Globe	32004629-001	Flowrite 599 Series	NPT	1/2 to 2	3/4	Q5020A,B and actuator to provide required torque ^c				
			Flanged	2 1/2 to 3						
Johnson Controls Valves										
Globe	32004629-002	VG7000	NPT	1/2 to 3/4	5/16 ^b	Q5020D	Q5020D	—	Q5020D	Q5020D
	32004629-003			1 to 1 1/4	1/2					
					1 1/2 to 2	3/4	Q5020A,B and actuator to provide required torque ^c			
Siebe (Barber Coleman) Valves										
Globe	32004629-004	VB7000	NPT	1/2 to 2	1/2	Q5020D	Q5020D	—	Q5020D	Q5020D

^a Single-seated Flange Valves larger than those shown require an ML6421B or ML7421B Direct Coupled Valve Actuator.

^b Use of a Q5020D (1/2 in. stroke) with a 5/16 in. stroke Johnson Controls valve allows the DCA hub to rotate only approximately 56° (not the full 90° stroke). This results in use of only 2/3 of the control signal through the full valve stroke. For modulating applications, this reduces control resolution. For two-position applications, reduced accuracy is not an issue.

^c Close-off ratings with Q5020 linkages and non-Honeywell valves are not included in this document. This value must be approximated using the Honeywell close-off rating information in Tables 3 and 4 as a reference. For example, an assembly with a 2 in. V5011N ($C_v = 46.8$) and a Q5020A with a 150 lb-in. non-spring return DCA provides 53 psid close-off. Using the same actuation package on a similar valve ($C_v = 40$) results in a close-off rating of approximately 62 psid ($46.8/40 \times 53 = 62$). However, there are many other factors involved in determining close-off ratings, so this method supplies only an approximation.

Table 3. Threaded Valve Close-Off Pressures (psid)^a.

Honeywell Valve					Honeywell Actuator Torque (lb-in.)							
Action	Type	Model	Size (in.)	Flow (C _v)	Non-Spring Return DCA				Spring Return DCA			
					35	70	150	300	25	53	142	
DA	2-way or 3-way	V5011N1 V5011N3 V5013N Water V5011N2 Steam ^b	1/2	2.9	230	230	230	230	159	230	230	
				4.7	143	230	230	230	95			
			3/4	7.4	69	156	230	230	44	114		
			1	12	47	109	225	230	29	79	219	
			1-1/4	16	29	69	144	230	17	49	141	
			1-1/2	29	17	44	94	180	9	31	92	
			2	47	8	24	53	103	4	16	52	
	2-way	V5011F Water V5011G Steam ^b	1/2	0.4-2.5	204	250	250	250	134	250	250	
				4	138	250	250	250	91	223		
			3/4	6.3	73	167	250	250	47	121		
			1	10	60	139	250	250	37	101		
			1-1/4	16	31	78	165	250	18	55	162	
			1-1/2	25	20	49	104	198	11	35	101	
			2	40	7	21	46	90	3	14	45	
2-1/2	63	5	16	38	74	2	11	37				
3	100	2	9	22	45	—	6	22				
RA	2-way	V5011H Water V5011J Steam ^b	1/2	2.5-4	58	125	250	250	39	93	246	
			3/4	6.3								
			1	10								
			1-1/4	16	41	88	177	250	28	65	173	
DA	3-way	V5013F	1/2	2.5-4	69	155	250	250	44	113	250	
			3/4	6.3								
			1	10	38	85	175	250	24	62	171	
			1-1/4	16	25	56	114	213	16	41	111	
			1-1/2	25	18	42	86	162	12	30	84	
			2	40	9	21	43	81	6	15	42	
	2-way	Double-seated V5047A	1	13	—	125	125	125	—	—	125	
			1-1/4	20								
			1-1/2	30								
2			50									

^a Check valve pressure ratings for the application.

^b The maximum differential pressure for steam valves is 100 psid.

NOTE: Close-off ratings are worst-case conditions; actual values are typically higher. Low values are for reference only.

Table 4. Flanged Valve Close-Off Pressures (psid)^a.

Honeywell Valve						Honeywell Actuator Torque (lb-in.)							
Medium	Type	Action	Description	Size (in.)	Flow (C _v)	Non-Spring Return				Spring Return			
						35	70	150	300	25	53	142	
Water	2-way	DA	V3350A, V3450A	2-1/2	63	4	10	22	42	2	7	22	
				3	100	3	7	15	28	2	5	14	
		RA	V3350C, 51C, V3450C, 51C	2-1/2	63	4	10	22	43	2	7	22	
				3	100	2	7	14	28	1	5	14	
	3-way	DA	V3360, 61E, V3460, 61E	2-1/2	63	4	10	22	43	2	7	22	
				3	100	2	7	14	28	1	5	14	
Steam	2-way	DA	V3350B,51B, V3450B,51B	2-1/2	63	3	9	21	41	1	6	20	
				3	100	2	6	14	27	1	4	13	
		RA	V3350D, V3450D	2-1/2	63	3	9	21	41	1	6	20	
				3	100	2	6	14	27	—	4	13	
	Water and Steam	2-way	DA	V5011A,D	2-1/2	63	8	21	46	88	5	15	45
					3	100	3	9	22	42	1	6	21
3-way		V5013B-E		2-1/2	63	8	21	46	88	5	15	45	
				3	100	3	9	22	42	1	6	21	
Cage Valve V5051	3-way	DA	Cage Valve V5051	2-1/2	75	—	—	—	50/150 ^b	—	—	50/150 ^b	
				3	116	—	—	—	—	—	—	—	
				4	178	—	—	—	—	—	—	—	
				5	318	—	—	—	—	—	—	—	
				6	390	—	—	—	—	—	—	—	

^a Check valve pressure ratings for the application.

^b 50 psid for brass trim, 150 psid for stainless steel trim.

NOTE: Close-off ratings are worst-case conditions; actual values are typically higher. Low values are for reference only.

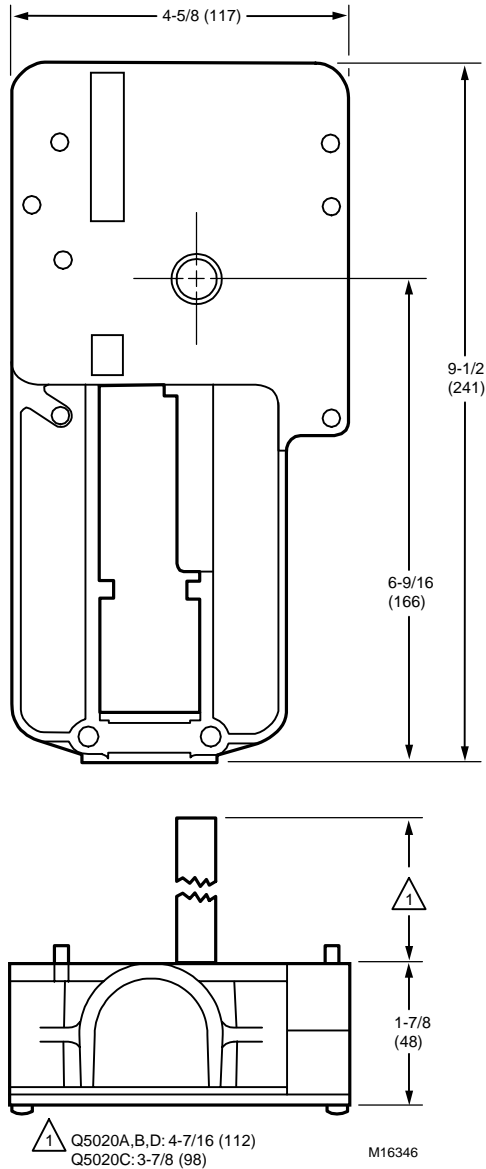

Fig. 1. Q5020 Dimensions in in. (mm).

INSTALLATION

When Installing this Product...

1. Read these instructions carefully. Failure to follow them could damage the product or cause a hazardous condition.
2. Check the ratings given in the instructions and on the product to make sure the product is suitable for your application.
3. Installer must be a trained, experienced service technician.
4. After installation is complete, check out product operation as provided in these instructions.

Location

Select a location where the valve, linkage, and motor will be within the environmental and ambient temperature ratings. See Specifications section.

NOTE: Allow approximately 12 in. clearance above the valve bonnet for installation and servicing.

Mounting

IMPORTANT

1. Ensure the valve stem stroke matches the Q5020 Linkage. See Table 1.
2. Mounting the Q5020 on a non-Honeywell valve requires the correct Bonnet Adapter Kit. See Table 2.

Preparation

When using a high-torque actuator (142 lb-in. or greater torque) a steel stem button is required. If the valve stem button is brass (for example, V5011N/V5013N Valves manufactured prior to March 1999, and V33XX/V34XX Valves), replace the brass stem button with the provided steel stem button:

1. Measure the stem button height (from the valve bonnet to the top of the button).
2. Loosen the set screw of the brass stem button.
3. Remove and discard the brass stem button.
4. Install the steel stem button.
5. Ensure stem button height is the same as in step 1.
6. Tighten the set screw of the steel button.

Installation

1. Ensure the valve stem operates freely. Impaired stem operation can indicate a twisted valve body or a bent stem. Either of these conditions can require valve replacement.
2. Place the Q5020 linkage over the valve bonnet while fitting the rack slot onto the valve stem button.
3. Ensure the linkage seats flush on the valve bonnet.

IMPORTANT

To ensure even pressure on the valve bonnet, first tighten the nuts finger-tight and then alternate turning each U-bolt nut until both are tight.

4. Assemble and tighten the U-bolt and nuts. When using a 35 or 70 lb-in. non-spring return actuator, discard the mounting plate and proceed to step 7.

NOTE: A 35 or 70 lb-in. non-spring return actuator fits between raised tabs in the cast housing to prevent rotation, eliminating the need for the mounting plate.

5. Using the included 3/4 in. long bolts, attach the actuator mounting plate to the housing so that it protrudes to either the left or the right side of the linkage, whichever is most convenient for installation. See Fig. 2.

IMPORTANT

Take care not to over-tighten the screws and strip the threads.

6. Attach the anti-rotation hardware to the actuator mounting plate. See Fig. 3 through 6.

NOTE: The Q5020 ships with extra hardware because each model accommodates using different actuators. Install the hardware compatible with your actuator. See Table 5. Discard unused hardware.

7. Put the actuator in place over the shaft but do not tighten the actuator hub screws.
8. Verify the valve stem stroke direction and actuator rotation direction are properly related. For example, assume a spring return actuator and a 2-way, stem-down-to-close, normally-closed valve are used together. With an unpowered actuator, the valve should be fully closed. To accomplish this, rotate the Q5020 shaft fully counterclockwise (as viewed from the front). This moves the valve stem fully downward so that rotating the shaft counterclockwise closes the valve.
9. Install the manual override handle on the linkage shaft. Tighten the nuts on the U-bolt. Rotate the handle to check the full stroke of the valve stem for smooth movement and handle clearance.

NOTE: The handle can aid in visualizing valve position attach the handle perpendicular to the piping with the valve closed. This should position the handle parallel to the piping with the valve open.

10. Set valve and linkage to the normal position. Note the valve stem position (up or down) for the next step:
 - a. 2-way valve: use the handle to fully close the valve.
 - b. 3-way valve: use the handle to fully close the valve to either seat.
11. Install the actuator approximately five degrees from its end stop with the valve fully seated. This ensures that the actuator closes the valve before it reaches its end-stop. See Table 5 to determine the proper method to obtain the five degree setting.
 - a. Valve stem fully down: actuator must be five degrees from the counterclockwise end stop.
 - b. Valve stem fully up: actuator must be five degrees from the clockwise end stop.
12. Position the actuator on the Q5020:
 - a. When using a 35 or 70 lb-in. actuator, ensure that the actuator is flush with the Q5020 housing, and located between the raised tabs.
 - b. For all other actuators, position the actuator approximately parallel to the mounting plate.
13. Tighten the actuator hub to the linkage shaft and install actuator control wiring. See the instructions provided with the actuator.

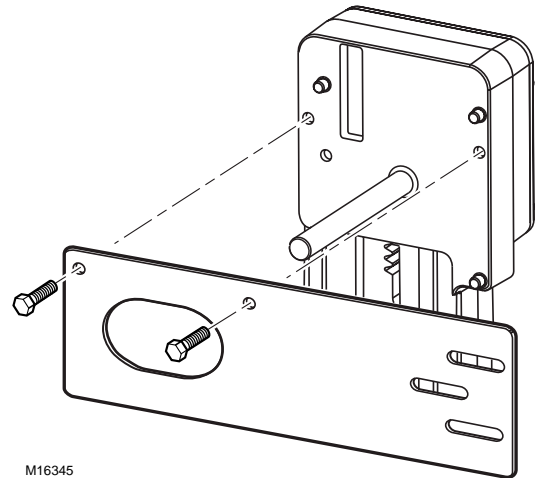

Fig. 2. Installing actuator mounting plate to Q5020.

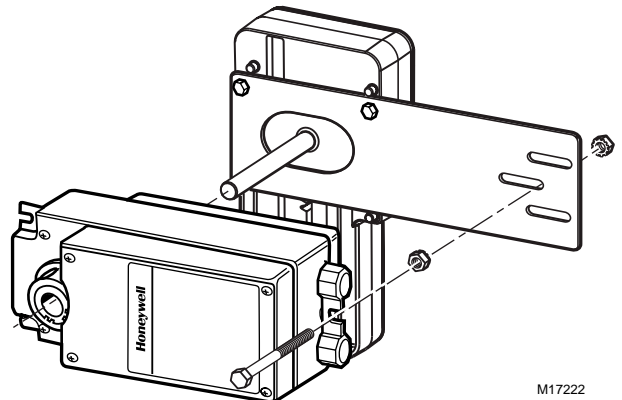

Fig. 3. Installing 25 or 53 lb-in. actuator.

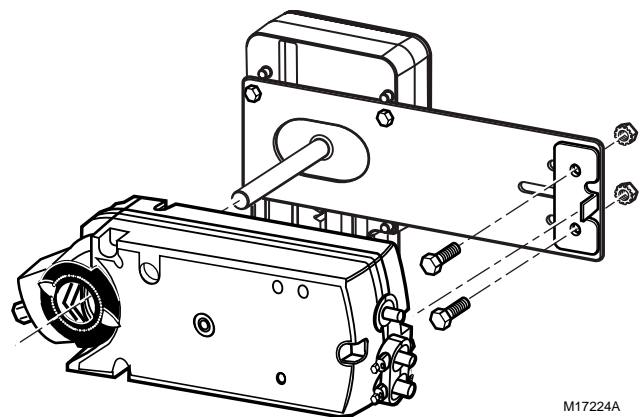

Fig. 4. Installing 142 lb-in. actuator.

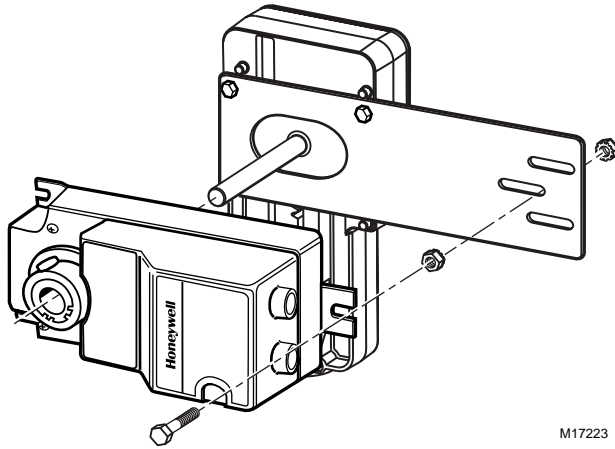

Fig. 5. Installing 150 or 300 lb-in. actuator.

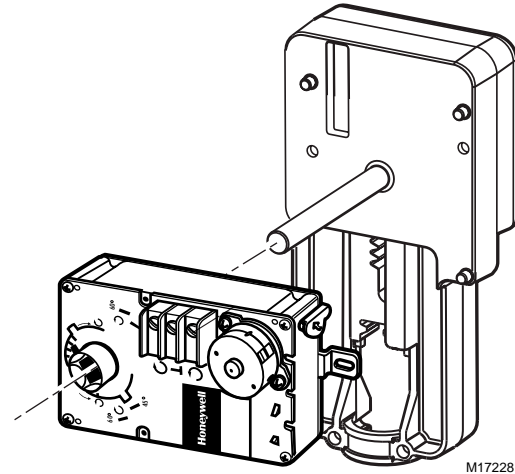

Fig. 6. Installing 35 or 70 lb-in. actuator.

CHECKOUT

After installing linkage and actuator, proceed as follows:

1. Apply power to the actuator.
2. Cycle the valve through at least one complete stroke to ensure proper operation.
3. Ensure that the valve seats before the actuator reaches the stroke end.

NOTE: 3-way valves must seat before the actuator reaches either end of the stroke.

4. If the valve does not travel or seat properly and is installed correctly, check Tables 2, 3, and 4. Ensure the valve, actuator, and linkage combination is correct for your application.
5. If the preceding troubleshooting steps do not locate the problem, check both the actuator and valve individually (see Checkout sections of the device instructions). For example, the actuator stroke may be impeded, or the valve stem button height may be out of adjustment.
6. If the valve and actuator operate properly, but the valve, actuator, and linkage combination does not, replace the linkage.

Table 5. Proper Anti-Rotation Assemblies and Actuator Position Adjustment Methods.

Actuator Type	Torque (lb-in.)	Anti-Rotation Assembly	Adjustment Method
Non-Spring Return	35, 70	Q5020 Housing ^a	De-clutch mechanism
	150, 300	1 in. long Bolt	
Spring Return	142	Bracket and 1/2 in. long Bolts (2)	Crank provided with actuator ^b
	25, 53	2-1/2 in. long Bolt	Power and drive actuator

^a 35 or 70 lb-in. non-spring return actuators do not require any anti-rotation assembly. The tabs molded into the Q5020 housing serve this purpose.

^b 142 lb-in. actuators arrive from the factory positioned 5 degrees off an end stop.

Home and Building Control

Honeywell Inc.
Honeywell Plaza
P.O. Box 524
Minneapolis, MN 55408-0524

Home and Building Control

Honeywell Limited-Honeywell Limitée
155 Gordon Baker Road
North York, Ontario
M2H 3N7

Honeywell Asia Pacific Inc.

Room 3213-3225
Sun Hung Kai Centre
No. 30 Harbour Road
Wanchai
Hong Kong

Honeywell Latin American Region

480 Sawgrass Corporate Parkway
Suite 200
Sunrise FL 33325

Honeywell Europe S.A.

3 Avenue du Bourget
1140 Brussels
Belgium

Honeywell

