

V5013N Three-Way Threaded Globe Valve

PRODUCT DATA

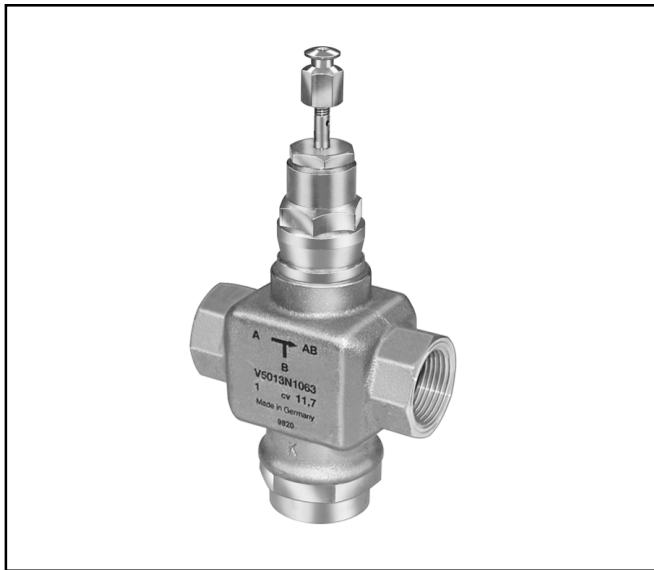

FEATURES

- Red brass body with NPT-threaded connections.
- Stainless steel stem and brass plug.
- Low seat leakage rate (≤ 0.05 percent C_v).
- Spring-loaded, self-adjusting packing.
- 50:1 rangeability per VDI/VDE 2173.
- Constant total flow throughout full stem travel.
- Accurate positioning to ensure state of the art temperature control.
- Sizes range from 1/2 inch to 2 inches.
- Suitable for pneumatic or electric/electronic actuation.
- Repack and rebuild kits available for field servicing.

APPLICATION

The V5013N is a three-way threaded globe valve that controls hot water, cold water, and glycol solutions (up to 50 percent concentration) in heating or cooling HVAC applications. The valve is used for mixing service to direct flow from one of two inlets to a common outlet in two-position or modulating control systems.

Contents

Application	1
Features	1
Specifications	2
Ordering Information	2
Installation	7
Checkout	8



SPECIFICATIONS

IMPORTANT

The specifications given in this publication do not include normal manufacturing tolerances. Therefore, an individual unit may not exactly match the listed specifications. Also, this product is tested and calibrated under closely controlled conditions and some minor differences in performance can be expected if those conditions are changed.

Models:

V5013N Valve: Three-way mixing valve for water or glycol. NPT-threaded pipe connections. Constant total flow. Push down valve stem to close bottom (B) port.

Valve Sizes and Flow Capacities:

See Table 1.

Table 1. Valve size and flow capacities.

Valve Body Pipe Size (in.)	Flow Capacity (C _v)
1/2	2.9
1/2	4.7
3/4	7.3
1	11.7
1-1/4	18.7
1-1/2	29.3
2	46.8

Pipe Connections:

Female NPT-threaded connections.

Motor and Linkage Selection:

Electric	Pneumatic
ML6421/ML6425	MP953
ML7421/ML7425	
ML7984/ML6874	
Mod IV w/Q5001	

Seat:

1/2 in.; Replaceable stainless steel (upper), replaceable brass (lower).

3/4 in. to 2 in.; Integral brass (upper), replaceable brass (lower).

ANSI Body Class:

150 psi.

Stem:

Stainless steel.

Plug:

Brass.

Stroke:

3/4 in. (20 mm).

Approximate Leakage Rate:

0.05 percent C_v.

Body Material:

Red brass.

Packing:

Spring-loaded, carbon fiber reinforced PTFE V-rings.

Pressure-Temperature Ratings:

Water: 36°F to 248°F, 227 psi.

248°F to 340°F, 211 psi.

Valve Flow Characteristics:

Equal percentage port A-AB, linear port B-AB. Movement of the valve stem at any point of the flow range does not significantly change the total flow rate at the AB outlet port (constant total flow).

Close-Off Pressure Ratings:

See Fig. 1 and Table 2.

ORDERING INFORMATION

When purchasing replacement and modernization products from your TRADELINE® wholesaler or distributor, refer to the TRADELINE® Catalog or price sheets for complete ordering number.

If you have additional questions, need further information, or would like to comment on our products or services, please write or phone:

1. Your local Home and Building Control Sales Office (check white pages of your phone directory).
2. Home and Building Control Customer Logistics
Honeywell Inc., 1885 Douglas Drive North
Minneapolis, Minnesota 55422-4386 (612) 951-1000

In Canada—Honeywell Limited/Honeywell Limitée, 155 Gordon Baker Road, North York, Ontario M2H 3N7.

International Sales and Service Offices in all principal cities of the world. Manufacturing in Australia, Canada, Finland, France, Germany, Japan, Mexico, Netherlands, Spain, Taiwan, United Kingdom, U.S.A.

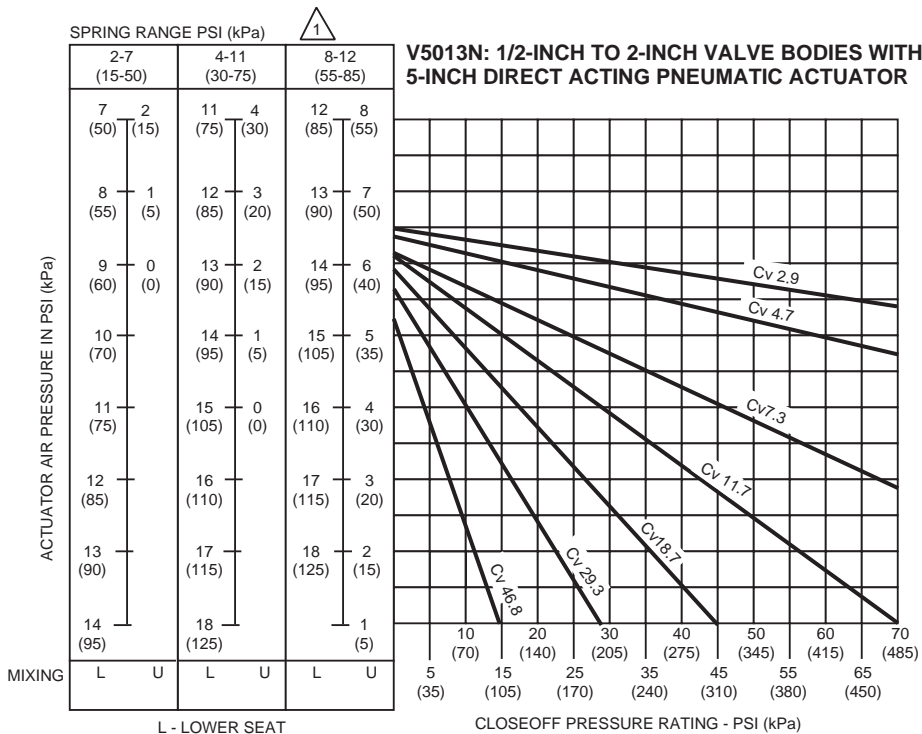

1 USE 4-11 PSI (30-75 kPa) RANGE FOR DETERMINING CLOSEOFF OF VALVES WITH MP953E ACTUATORS.

M12909

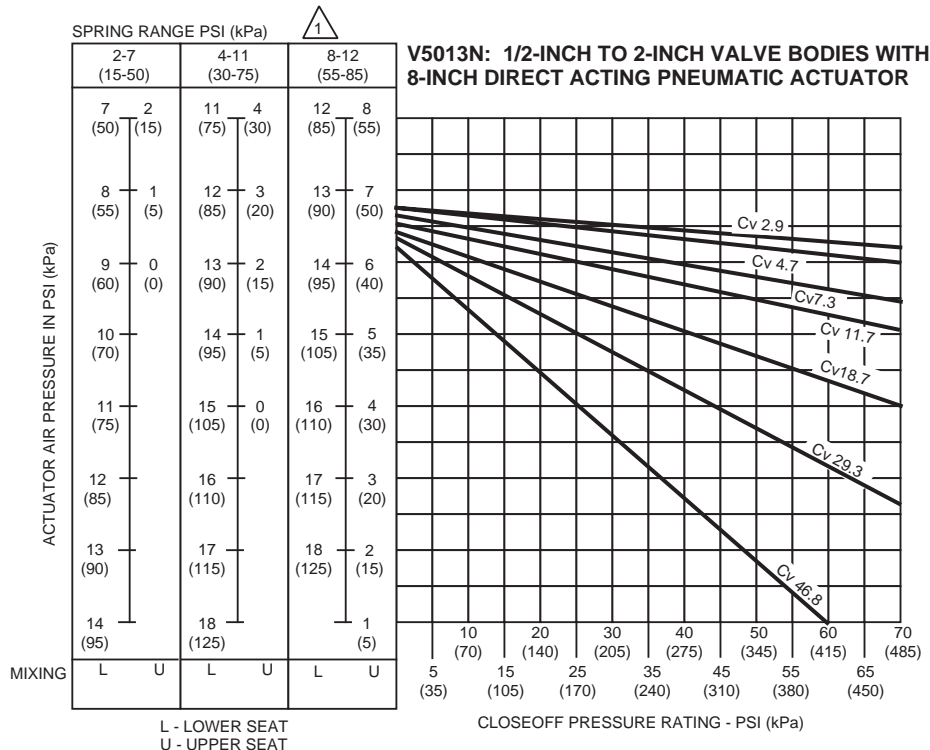

1 USE 4-11 PSI (30-75 kPa) RANGE FOR DETERMINING CLOSEOFF OF VALVES WITH MP953E ACTUATORS.

M12908

Fig. 1. Close-off pressures at various control air pressures for V5013N Valves and MP953 Pneumatic Actuators.

continued

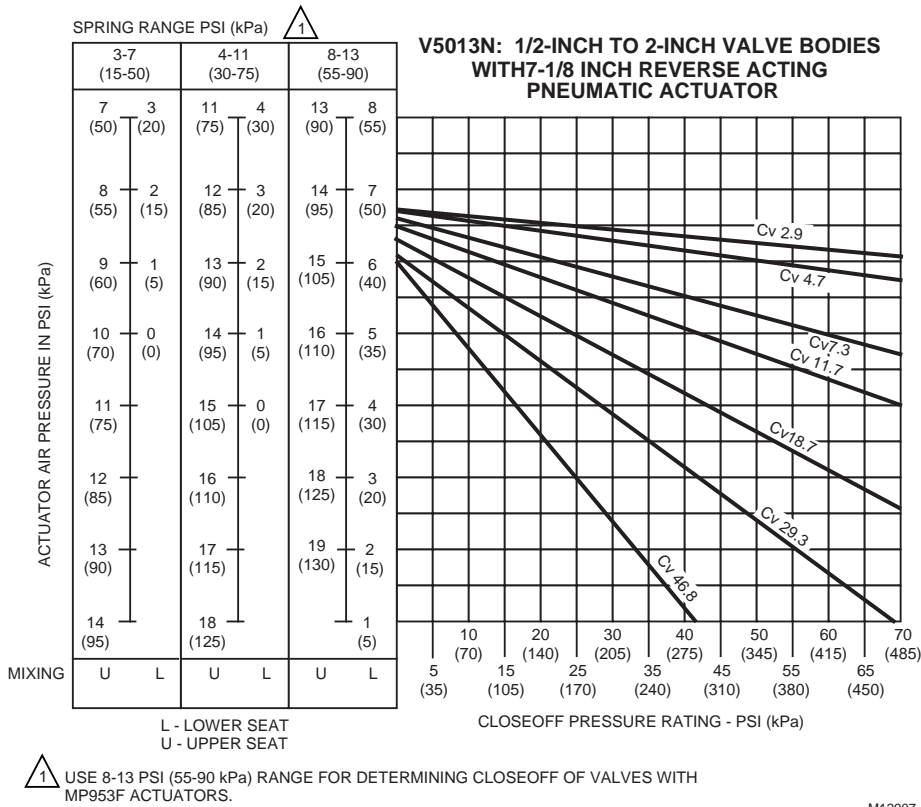

Fig. 1. Close-off pressures at various control air pressures for V5013N Valves and MP953 Pneumatic Actuators (continued).

Table 2. Close off ratings (psid) for V5013N Valves with electric/electronic actuators and Q5001 Linkages.

Valve Size (NPT)	Mod IV Motor with Q5001 Linkages			ML6421A,B ML7421A,B	ML6425A,B ML7425A,B	ML7984, ML6874
	320 lb	160 lb	80lb	405 lb	135 lb	160 lb
1/2 in. ($C_v = .73$ to 2.9)		230 ^a	230 ^a		230 ^a	230 ^a
1/2 in. ($C_v = 4.7$)		230 ^a	230 ^a		230 ^a	230 ^a
3/4		230 ^a	131		230 ^a	230 ^a
1	230 ^a	196	91	230 ^a	163	196
1-1/4	230 ^a	126	57	230 ^a	104	126
1-1/2	173	81	36	221	67	81
2	98	46	19	126	37	46

^a Pressure limited by fluid temperature; see valve temperature/pressure ratings.

Maximum Pressure Differential for Quiet Water Service:
20 psi differential.

Rangeability:
50:1 per VDI/VDE 2173.

Dimensions:
See Fig. 2.

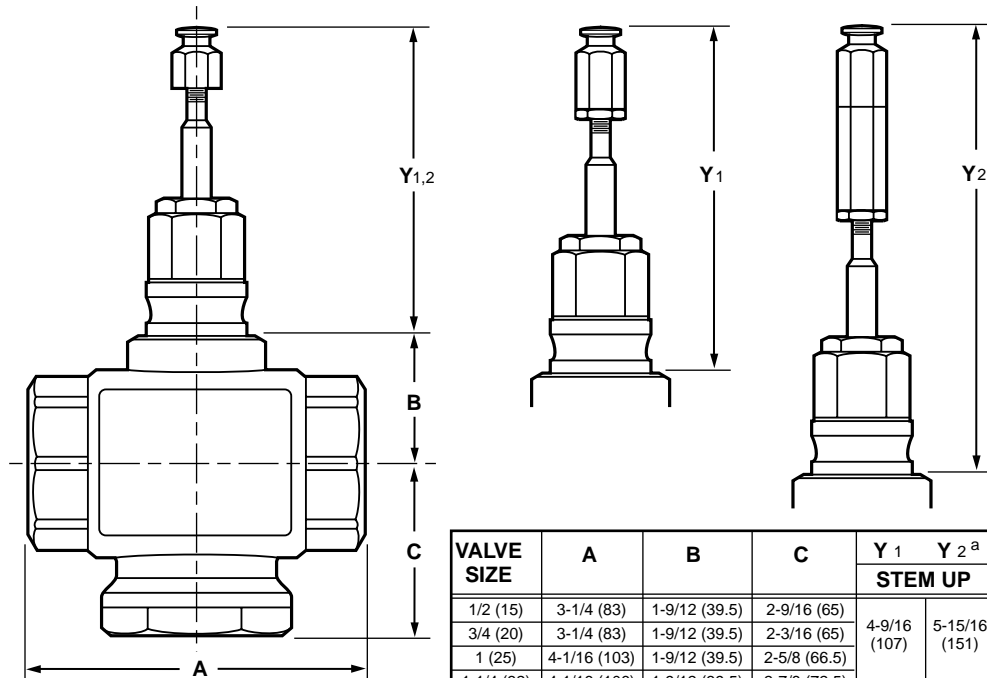

VALVE SIZE	A	B	C	Y 1 Y 2 ^a	
				STEM UP	
1/2 (15)	3-1/4 (83)	1-9/12 (39.5)	2-9/16 (65)	4-9/16 (107)	5-15/16 (151)
3/4 (20)	3-1/4 (83)	1-9/12 (39.5)	2-3/16 (65)		
1 (25)	4-1/16 (103)	1-9/12 (39.5)	2-5/8 (66.5)		
1-1/4 (32)	4-1/16 (106)	1-9/12 (39.5)	2-7/8 (72.5)		
1-1/2 (40)	4-3/4 (120)	1-13/16 (46.5)	3 (77)		
2 (50)	5-1/4 (134)	1-13/16 (46.5)	3-5/16 (83.5)		

NOTE: Y1 DIMENSION IS WITH STEM FULLY UP, NOT DOWN.

^aY2 WITH STEM EXTENSION FOR MP953A,C (8 IN. ONLY)

M12901

Fig. 2. V5013N body dimensions in in. (mm).

Replacement Parts:

See Fig. 3.

Valve OS No.	NPT Size (in.)	Flow Capacity (Cv)	Stem Diameter (in.)	Repack Kit (Part No.)	Rebuild Kit (Part No.)	Stem Button (Part No.)
V5013N1030	1/2	2.9	1/4	0901786	0901759A	0901116
V5013N1048		4.7			0901760A	
V5013N1055	3/4	7.3			0901761A	
V5013N1063	1	11.7			0901762A	
V5013N1071	1-1/4	18.7			0901763A	
V5013N1089	1-1/2	29.3			3/8	
V5013N1097	2	46.8	0901765A			

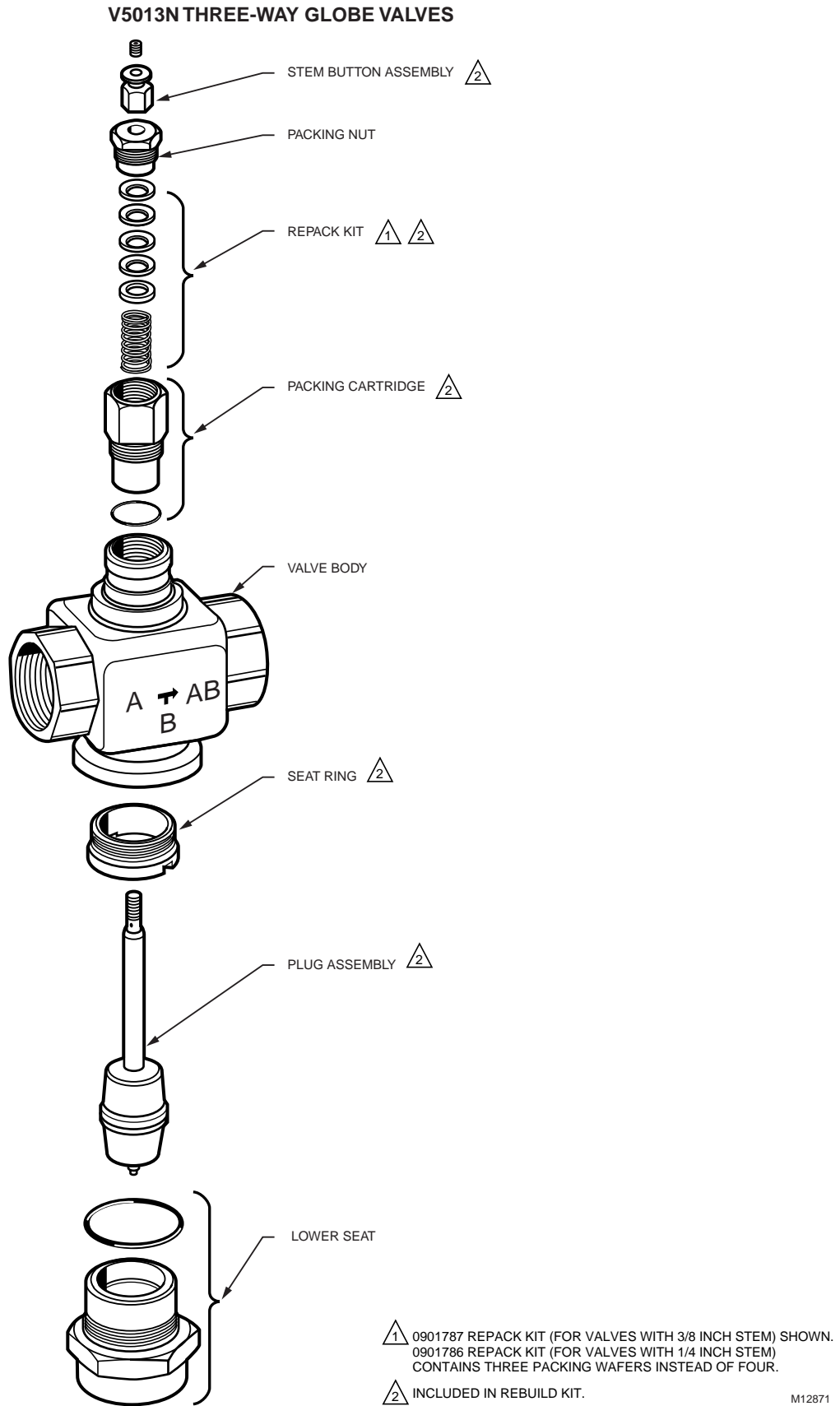

Fig. 3. V5013N replacement parts.

INSTALLATION

When Installing this Product...

1. Read these instructions carefully. Failure to follow them could damage the product or cause a hazardous condition.
2. Check the ratings given in the instructions and on the product to make sure the product is suitable for your application.
3. Installer must be a trained, experienced service technician.
4. After installation is complete, check out product operation as provided in these instructions.

IMPORTANT

1. Do not lift the valve by holding the stem.
2. Do not mount the valve with the stem pointed lower than horizontal.
3. Mount the valve with the flow arrow pointed in the direction of flow through the valve.
4. Mount the valve between aligned pipes. Mounting the valve on pipes that are not aligned causes leakage at the valve to pipe connection.
5. Ensure complete engagement on pipe to valve body threads.
6. Hold the valve body with a clamp or pipe wrench on the hexagonal fitting nearest the pipe to prevent damage to the valve body while mounting on the pipe. Refer to Fig. 7.
7. Be sure to allow enough room for installation and service. Clearance for valve installation is dependent on the actuator size and valve pipe size.

Location

Select a location where the valve, linkage (if used), and actuator to be used are within the appropriate ambient pressure and temperature ratings.

Leave sufficient clearance above the valve to accommodate actuator installation and room for servicing the valve body. (Completely install the valve body in the pipe line before installing the actuator and linkage.)

When selecting a location for the valve, consider actuator mounting restrictions. Modutrol IV™ Motors require crankshafts to be mounted horizontally.

Mounting

The preferred mounting position of the valve is with the stem vertical. Do not mount the valve with the stem more than 90 degrees from the vertical (pointing lower than horizontal). Scale and foreign material can collect and can score the stem and cause packing leakage. Protect the stem from damage due to bending or scratching.

Piping Hookups

All piping must comply with local codes and ordinances. Refer to Fig. 4 through 6 for typical piping hookups.

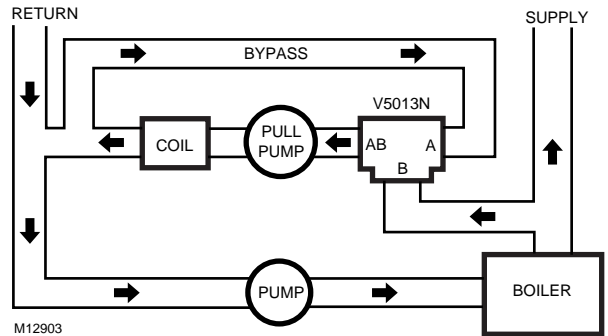

Fig. 4. Typical V5013N mixing valve with constant volume through coil.

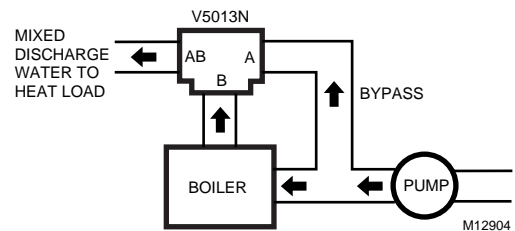

Fig. 5. Single zone bypass for reset control.

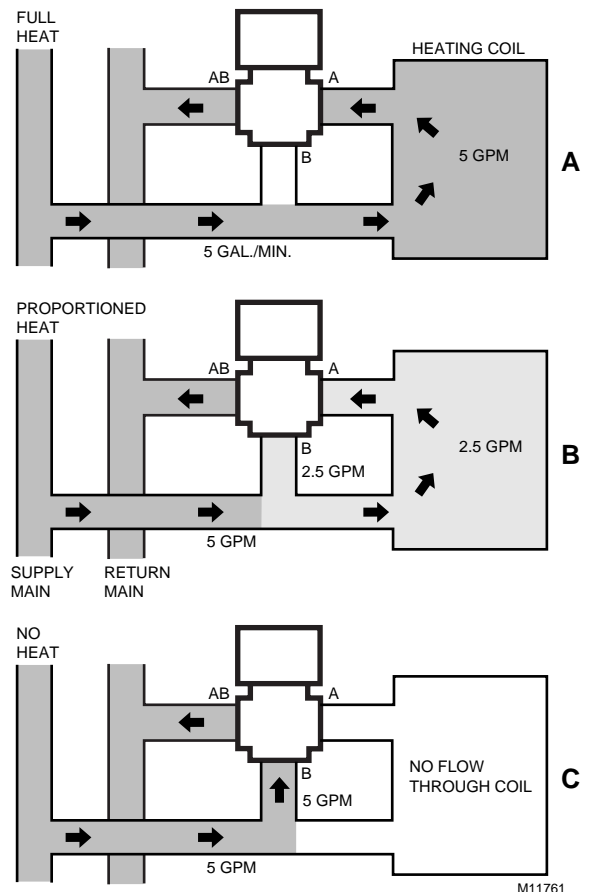

Fig. 6. Three-way mixing valve operation with coil bypass. Three-way valves maintain constant flow in piping. As temperature requirements change, volume of fluid varies in the coil.

Threaded Valve Bodies

Threading on threaded bodies conform to American Standard Taper Pipe Threads (NPT).

NOTE: Installing a strainer is strongly recommended.

Align the pipes squarely with the valve at each end connection. If the pipes are forced into the valve, the body can become twisted and improper seating can result. Apply pipe dope sparingly. Be careful to prevent pipe debris, such as pipe chips and scale, from entering the piping because this material can lodge in the seat and prevent proper closing.

Refer to Fig. 7 for valve pipe sizes and thread lengths. Fig. 7 also shows two effective methods of holding the valve and pipe when attaching it. The valve will not function properly if twisted or squeezed during installation.

Refer to installation information furnished with the linkage and motor when installing these controls.

CHECKOUT

Before installing linkage (if used) and actuator, be sure that valve stem operates freely. Impaired stem operation can indicate that the body was twisted or the stem bent. Either of these conditions can require valve replacement.

Check valve body and connections for leaks. After installing linkage and actuator, check the operation according to installation information provided with these controls. Operate the system through one complete cycle to be sure the valve controls properly.

Check the valve at regular intervals for leakage around packing. The packing is spring-loaded and should seldom require attention. If leakage is discovered and inspection shows that the packing gland is tightened properly, repack the valve.

Home and Building Control

Honeywell Inc.
Honeywell Plaza
P.O. Box 524
Minneapolis MN 55408-0524

Honeywell Latin American Region

480 Sawgrass Corporate Parkway
Suite 200
Sunrise FL 33325

Home and Building Control

Honeywell Limited-Honeywell Limitée
155 Gordon Baker Road
North York, Ontario
M2H 3N7

Honeywell Europe S.A.

3 Avenue du Bourget
1140 Brussels
Belgium

PIPE SIZE (IN.)	EFFECTIVE LENGTH OF THREADS IN IN. (MM)	
1/2	1/2	(12.7)
3/4	9/16	(14.3)
1	11/16	(17.5)
1-1/4	11/16	(17.5)
1-1/2	11/16	(17.5)
2	3/4	(19.1)

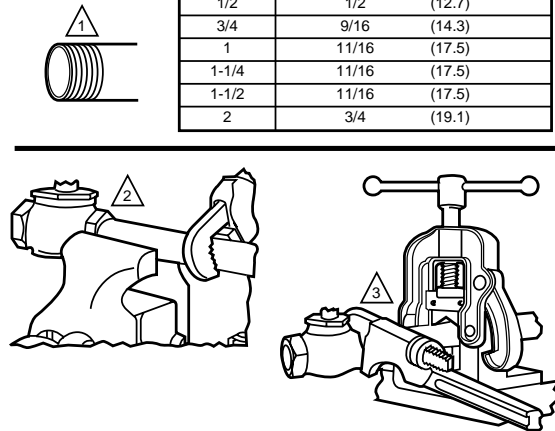

- 1 USE PROPERLY REAMED AND CLEANED PIPE AND MODERATE AMOUNT OF DOPE (LEAVE TWO THREADS BARE).
- 2 USE VISE GRIPS WITH THE HEX END NEXT TO THE PIPE (DO NOT TWIST OR SQUEEZE VALVE BODY).
- 3 USE VISE TO HOLD PIPE SECURELY TO PREVENT TURNING. USE PARALLEL-JAW WRENCH TO GRIP VALVE HEX FLATS NEXT TO PIPE.

M11763A

Fig. 7. Installing valves with threaded connections.

Honeywell Asia Pacific Inc.

Room 3213-3225
Sun Hung Kai Centre
No. 30 Harbour Road
Wanchai
Hong Kong

Honeywell

