

## V5013B,C,F Three-Way Mixing and Diverting Valves

### PRODUCT DATA



### FEATURES

- Mixing or diverting models.
- Bronze body with threaded connections or cast iron body with flanged-end connections.
- Stainless steel stem and replaceable seats.
- Spring-loaded, self-adjusting packing.
- Constant total flow throughout full stem travel.
- Linear flow characteristic for each port, providing constant total flow control of water or glycol solutions (up to 50% concentration).
- Suitable for pneumatic or electric/electronic actuation.
- Repacking kits available for field servicing.

### APPLICATION

The V5013 is a three-way valve for control of hot water, cold water, and glycol solutions (up to 50% concentration) in heating or cooling applications. These valves are used in two-position or modulating control systems. They can be used for mixing service (V5013B and F) to direct flow from one of two inlets to a common outlet or for diverting service (V5013C) to direct flow from a common inlet to one of two outlets.

Mixing and diverting valves are not interchangeable.

### Contents

Application .....	1
Features .....	1
Specifications .....	2
Ordering Information .....	2
Installation .....	4
Operation .....	6
Checkout .....	6



## SPECIFICATIONS

**Models:**  
See Table 1.

**Dimensions:**  
See Fig. 1 and 2 and Table 2.

**Flow Characteristics:**  
Linear, constant total flow throughout full plug travel.

**Valve Pressure-Temperature Ratings:**  
See Fig. 3.

**Close-Off Ratings:**  
Dependent on actuator (see Valve Selection Guide, form 68-8038).

**Maximum Pressure Differential (for Normal Plug and Seat Life):**  
Two-position service: 50 psi (345 kPa).  
Modulating service: 25 psi (172 kPa).  
Quiet Water service: 20 psi (138 kPa).

**Stem Travel:**  
1/2- to 3-in. Valves: 3/4 in. (19 mm).  
4-, 5-, and 6-in. Valves: 1-1/2 in. (38 mm).

### Materials:

**Body:**  
Threaded Valves: Bronze.  
Flanged Valves: Cast iron.  
**Stem:** Stainless steel.  
**Packing:**  
V5013B & C: Teflon cone for ANSI Class 125 flanged valves.  
V5013F: Rubber or teflon/rubber for ANSI Class 150 threaded valves.  
**Disc and Plug:**  
V5013B, C: Bronze-skirted plug.  
V5013F: Linear contour plug, one piece brass construction for metal-to-metal seating.  
**Seat:**  
V5013B: Bronze, removable cage type.  
V5013F: Integral brass.

### Accessories:

**Actuator Assemblies:** See the Valve Selection Guide, form 63-8038.  
**Repack Kits:**  
14003294-004 TRADELINE Kit for 1/2 in., 3/4 in., 1 in. and 1-1/4 in. threaded V5013A,F Valves.  
14003295-004 For 1-1/2 in., 2 in. threaded V5013A,F and 2-1/2 in. and 3 in. flanged V5013B,C Valves.  
14003296-002 For 4 in., 5 in., and 6 in. flanged V5013B,C Valves.  
14000501-001 Valve Bonnet Extension Kit. Further separates the actuator from the valve body for high-temperature applications.

## ORDERING INFORMATION

When purchasing replacement and modernization products from your TRADELINE® wholesaler or distributor, refer to the TRADELINE® Catalog or price sheets for complete ordering number.

If you have additional questions, need further information, or would like to comment on our products or services, please write or phone:

1. Your local Home and Building Control Sales Office (check white pages of your phone directory).
2. Home and Building Control Customer Logistics  
Honeywell Inc., 1885 Douglas Drive North  
Minneapolis, Minnesota 55422-4386 (612) 951-1000

In Canada—Honeywell Limited/Honeywell Limitée, 155 Gordon Baker Road, North York, Ontario M2H 3N7.  
International Sales and Service Offices in all principal cities of the world. Manufacturing in Australia, Canada, Finland, France, Germany, Japan, Mexico, Netherlands, Spain, Taiwan, United Kingdom, U.S.A.

Table 1. Model Descriptions and Body Specifications.

Model	Straight-through Flow	End Connections	ANSI Body Class	Body Size (in.)	Capacity Index (Cv)
V5013F Mixing	Stem Down	Threaded Female NPT	150	1/2	2.5, 4.0
				3/4	6.3
				1	10
				1-1/4	16
				1-1/2	25
				2	40
V5013B Mixing	Stem Down	Flanged	125	2-1/2	63
V5013C Diverting	Stem Up			3	100
				4	160
				5	250
				6	360

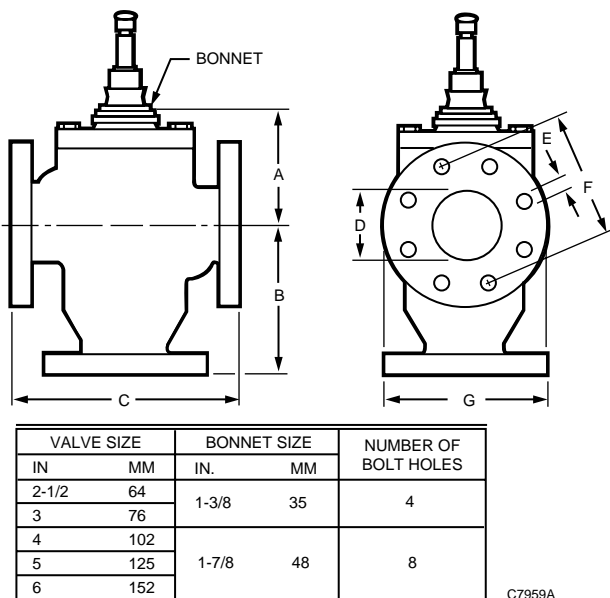

Fig. 1. V5013B,C Flanged Body Dimensions.

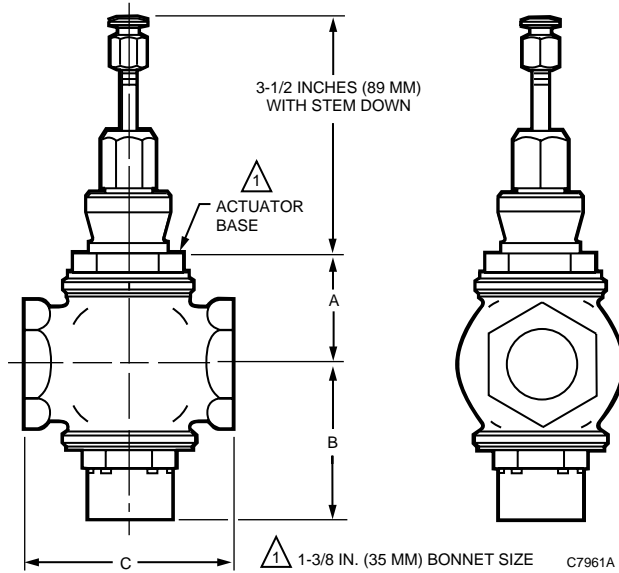

Fig. 2. V5013F Threaded Body Dimensions.

Table 2. V5013B,C,F Approximate Dimensions in Inches (Millimeters).

Model	Size in Inches	A	B	C	D	E	F	G
V5013B,C Fig. 1	2-1/2	4-1/2 (114)	6-7/17 (164)	9-1/2 (241)	2-1/2 (64)	3/4 (19)	5-1/2 (140)	7 (178)
	3	5-1/4 (133)	6-5/8 (168)	11 (279)	3 (76)	3/4 (19)	6 (152)	7-1/2 (191)
	4	5-7/8 (149)	8-11/16 (221)	13 (330)	4 (102)	3/4 (19)	7-1/2 (191)	9 (229)
	5	6-1/4 (159)	9-5/8 (244)	15 (381)	5 (127)	7/8 (22)	8-1/2 (216)	10 (254)
	6	7-1/4 (184)	10-11/16 (271)	16-1/2 (419)	6 (152)	7/8 (22)	9-1/2 (241)	11 (279)
	V5013F Fig. 2	1/2	1-3/4 (44)	2-5/8 (67)	3-1/2 (89)	-	-	-
3/4		1-3/4 (44)	2-1/2 (64)	3-3/8 (86)	-	-	-	-
1		1-7/8 (48)	2-5/8 (67)	3-7/8 (98)	-	-	-	-
1-1/4		2 (51)	2-5/8 (67)	4-1/4 (108)	-	-	-	-
1-1/2		2-3/8 (60)	2-3/4 (70)	4-3/4 (121)	-	-	-	-
2		2-5/8 (67)	3-1/8 (79)	5-7/8 (149)	-	-	-	-

## INSTALLATION

### When Installing this Product...

1. Read these instructions carefully. Failure to follow them could damage the product or cause a hazardous condition.
2. Check the ratings given in the instructions and on the product to make sure the product is suitable for your application.
3. Installer must be a trained, experienced service technician.
4. After installation is complete, check out product operation as provided in these instructions.

### IMPORTANT

Install the valve so the fluid flows in the direction of the arrow cast on the body. Mount the valve with the operator motor shaft horizontal.

### Location

In selecting a location, the following must be considered.

1. Make sure sufficient space has been provided for the complete valve assembly. The actuator assembly fits over the valve stem.
2. The actuator assembly should not be mounted below the valve where moisture or dirt may accumulate.

The ambient temperature must not exceed the maximum limits for the valve or motor. Controlled liquid-pressure must not exceed the maximum pressure limits of the valve.

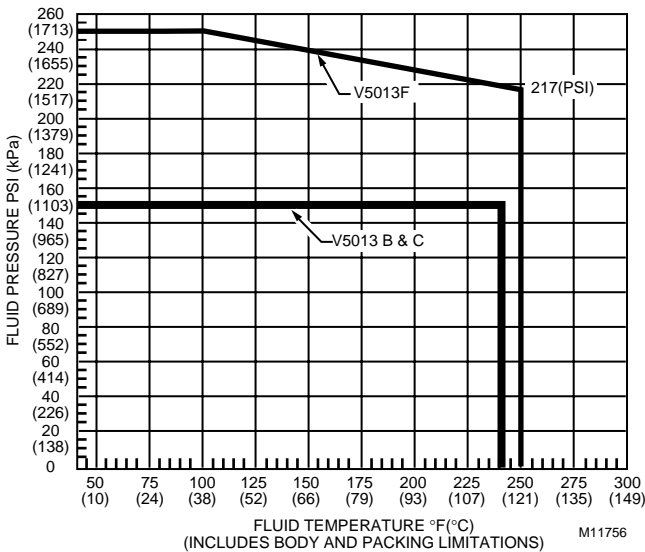

Fig. 3. Valve pressure-temperature ratings.

### Piping Hookups

All piping must comply with local codes and ordinances. Refer to Fig. 4-8 for typical piping hookups.

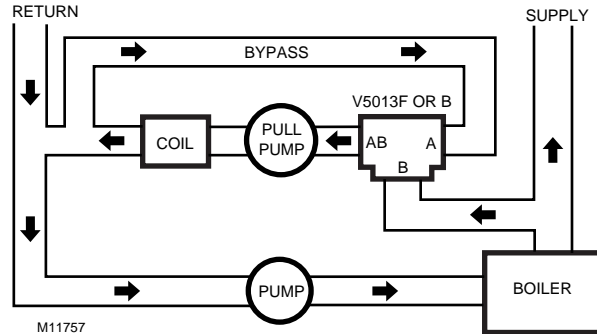

Fig. 4. Typical V5013F or B mixing valve with constant volume through coil.

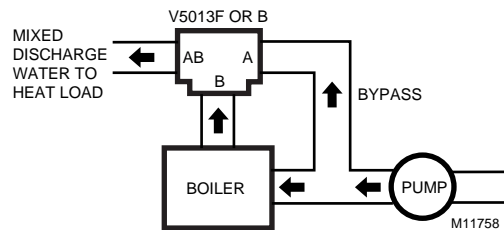

Fig. 5. Single zone bypass for reset control.

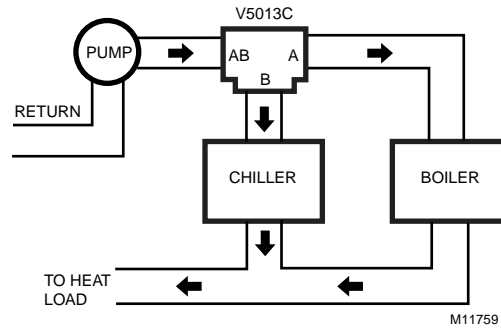
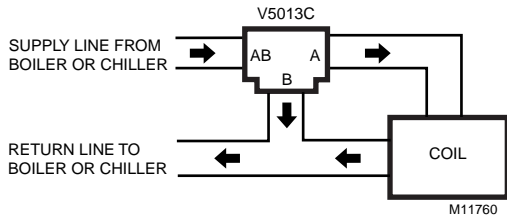
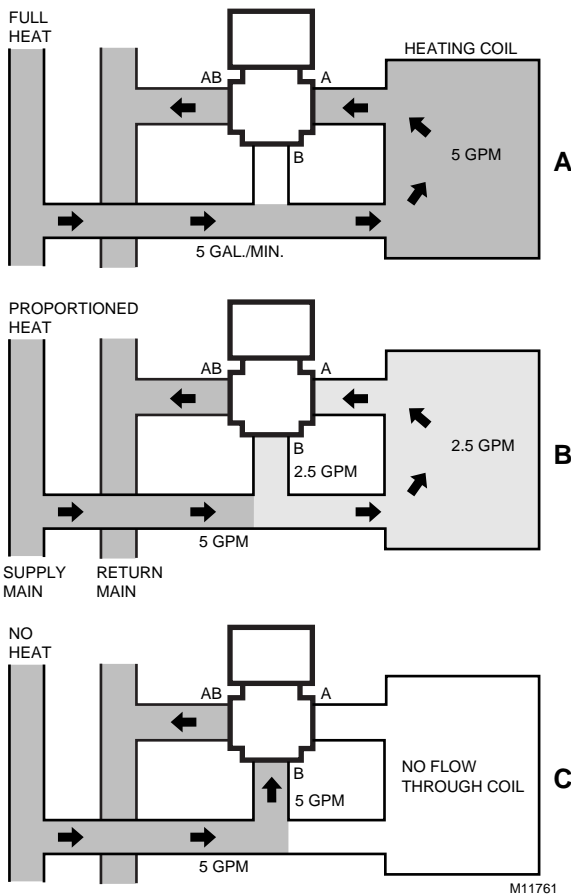

Fig. 6. V5013C diverting valve used to change over complete system.



**Fig. 7. Typical zone hookup of V5013C diverting valve used to control flow through coil.**

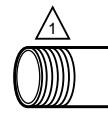

**Fig. 8. Three-way mixing valve operation—coil bypass. Three-way valves maintain constant flow in the piping. As the temperature requirements change, the volume of the fluid in the coil varies.**

## Valve Installation

### Threaded Valve bodies

Line up the pipes squarely with the valve at each end. If the pipes are forced into the valve, the body may become twisted and improper seating will result. Prevent pipe chips, scale, and dirt from entering the piping since they may lodge in the seat and prevent proper closing. Apply a vise or wrench to the valve (see Fig. 9).



PIPE SIZE (INCHES)	EFFECTIVE LENGTH OF THREADS (INCHES) [MILLIMETERS]	
1/2	1/2	[12.7]
3/4	9/16	[14.3]
1	11/16	[17.5]
1-1/4	11/16	[17.5]
1-1/2	11/16	[17.5]
2	3/4	[19.1]

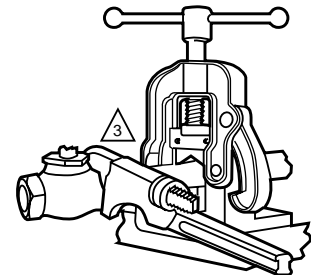
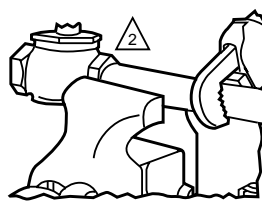

- 1 USE PROPERLY REAMED AND CLEANED PIPE AND MODERATE AMOUNT OF DOPE (LEAVE TWO THREADS BARE).
- 2 VISE GRIPS HEX END NEXT TO PIPE (DO NOT TWIST OR SQUEEZE VALVE BODY).
- 3 VISE HOLDS PIPE SECURELY AGAINST TURNING AND PARALLEL JAW WRENCH GRIPS VALVE HEX FLATS NEXT TO PIPE. M11763

**Fig. 9. Mounting of threaded valve bodies.**

### Flanged Valve Bodies

The valve flanges are flat faced with a smooth finish. Companion flanges must be of the same specifications. Mounting bolts must be long enough to allow nuts to utilize the full length of the nut threads.

The bolts should be approximately 1/8 in. (3 mm) smaller than the diameter of the bolt hole to allow clearance for installing. To prevent leakage, use a gasket material recommended for the medium to be handled.

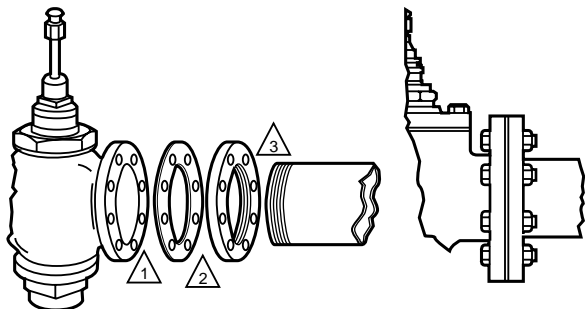

- 1 DO NOT APPLY PIPE DOPE TO VALVE FLANGE, COMPANION FLANGE OR GASKET.
- 2 BE SURE FACE OF COMPANION FLANGE IS FLUSH WITH FACE OF VALVE-BODY FLANGE AND ALIGNED SQUARELY BEFORE TIGHTENING MOUNTING NUTS.
- 3 IF POSSIBLE, MOUNT COMPANION FLANGE ON PIPE BEFORE MOUNTING FLANGE ON THE VALVE.

M11764

**Fig. 10. Mounting of flanged valve bodies.**

**NOTE:** For V5013F and B, if the pressures in the pipe lines at inlets A and B are unequal, a balancing cock may be installed in the line carrying the higher pressure. Best possible modulation will be obtained if this cock is adjusted under actual operating conditions so that pressures A and B are equal at midstroke.

## OPERATION

### Mixing and Diverting

It is important to understand the differences between mixing valves (V5013B,F) and diverting valves (V5013C). When applied to valves, the terms *mixing* and *diverting* do not always carry the same connotation as when applied to applications. Namely, a *mixing application* does not always use a *mixing valve*. The type of valve used is dependent upon the piping of the application.

### Valves

A mixing valve receives input flow at two ports, and discharges the mixed flow at the third port. A diverting valve receives input flow at one port, and diverts the flow to one of two output ports.

#### **IMPORTANT**

*V5013 Valves should not be piped backwards.*

### Applications

The terms *diverting application* and *mixing application* do not always clearly define the appropriate V5013. The proper V5013 depends on the valve piping. One example of this is the coil bypass application (see Fig. 7 and 8). A diverting valve installed upstream of the coil determines the flow through the coil (see Fig. 7). This is functionally the same as a mixing valve installed downstream of the coil directing water from either the coil or the bypass to the return piping (see Fig. 8). Almost all new installations can use a V5013B,F Mixing Valve, given an appropriate mixing valve piping arrangement.

## CHECKOUT

It is important to check the valve stem to see that it operates freely. Impaired valve stem operation may indicate that the body was twisted by faulty piping or the stem was bent by rough handling. Either of these conditions may warrant replacement of the valve body or other components.

The valve should be checked at regular intervals for leakage around the packing. The packing is spring-loaded and should seldom require attention. If leakage is discovered and inspection shows that the packing gland is screwed down tightly, the valve must be repacked.

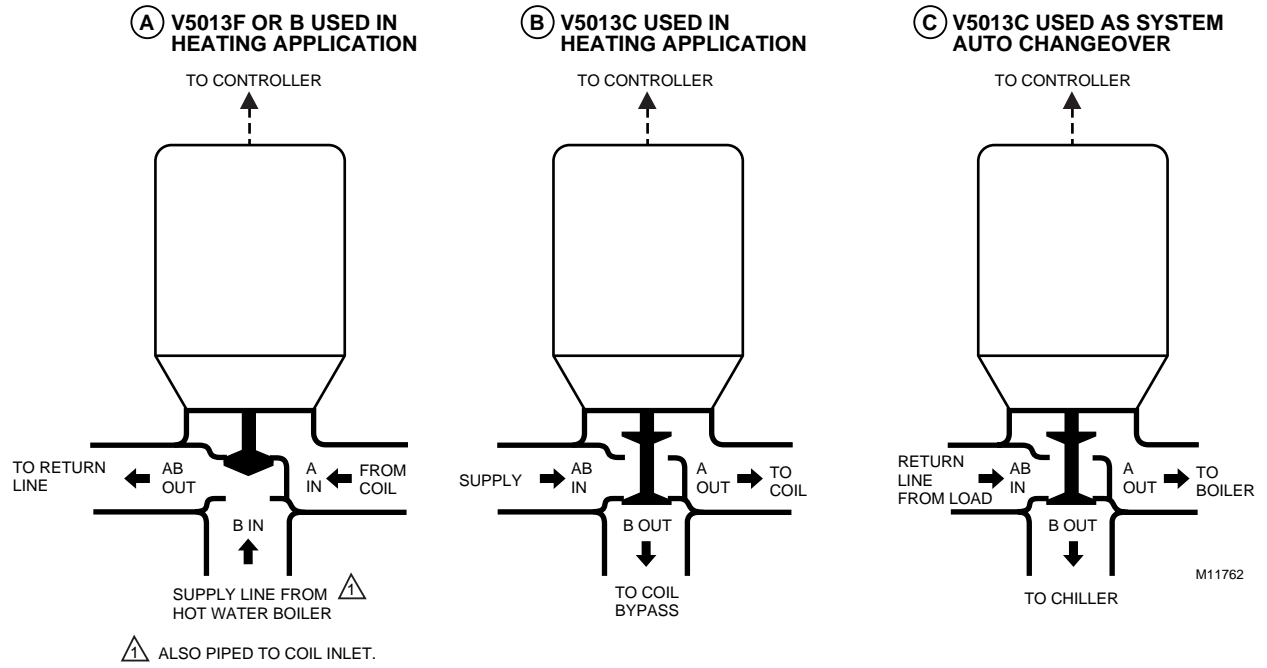

Fig. 11. V5013B,C,F valve hookups.

**Home and Building Control**

Honeywell Inc.  
Honeywell Plaza  
P.O. Box 524  
Minneapolis MN 55408-0524

**Honeywell Latin American Region**

480 Sawgrass Corporate Parkway  
Suite 200  
Sunrise FL 33325

**Home and Building Control**

Honeywell Limited-Honeywell Limitée  
155 Gordon Baker Road  
North York, Ontario  
M2H 3N7

**Honeywell Europe S.A.**

3 Avenue du Bourget  
1140 Brussels  
Belgium

**Honeywell Asia Pacific Inc.**

Room 3213-3225  
Sun Hung Kai Centre  
No. 30 Harbour Road  
Wanchai  
Hong Kong

---

**Honeywell**

